

**Version 1.1**

Manual Rev: 1.1  
Release Date: Jun. 2002



### **FCC-B Radio Frequency Interference Statement**

This equipment has been tested and found to comply with the limits for a class B digital device, pursuant to part 15 of the FCC rules. These limits are designed to provide reasonable protection against harmful interference when the equipment is operated in a commercial environment. This equipment generates, uses and can radiate radio frequency energy and, if not installed and used in accordance with the instruction manual, may cause harmful interference to radio communications. Operation of this equipment in a residential area is likely to cause harmful interference, in which case the user will be required to correct the interference at his own expense.

#### **Notice 1**

The changes or modifications not expressly approved by the party responsible for compliance could void the user's authority to operate the equipment.

#### **Notice 2**

Shielded interface cables and A.C. power cord, if any, must be used in order to comply with the emission limits.

**VOIR LA NOTICE D'INSTALLATION AVANT DE RACCORDER AU RESEAU.**

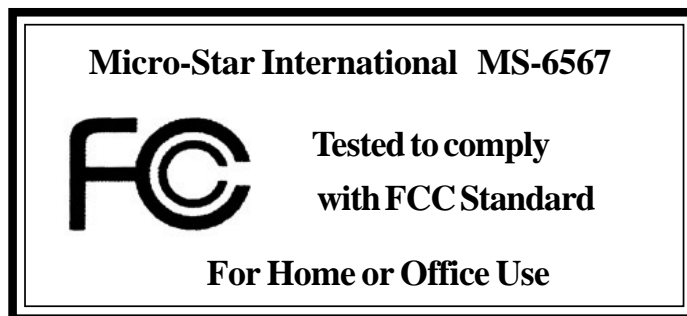

## **Edition**

Jun. 2002

## **Copyright Notice**

The material in this document is the intellectual property of **MICRO-STAR INTERNATIONAL**. We take every care in the preparation of this document, but no guarantee is given as to the correctness of its contents. Our products are under continual improvement and we reserve the right to make changes without notice.

## **Trademarks**

All trademarks are the properties of their respective owners.

Intel® and Pentium® are registered trademarks of Intel Corporation.

PS/2 and OS®/2 are registered trademarks of International Business Machines Corporation.

Windows® 95/98/2000/NT/ME/XP are registered trademarks of Microsoft Corporation.

Netware® is a registered trademark of Novell, Inc.

Award® is a registered trademark of Phoenix Technologies Ltd.

AMI® is a registered trademark of American Megatrends Inc.

## **Revision History**

<b>Revision</b>	<b>Revision History</b>	<b>Date</b>
1.0	First Release	Mar. 2002
1.1	Use SiS962L instead of SiS 961 B	Jun. 2002

## Safety Instructions

1. Always read the safety instructions carefully.
2. Keep this User's Manual for future reference.
3. Keep this equipment away from humidity.
4. Lay this equipment on a reliable flat surface before setting it up.
5. The openings on the enclosure are for air convection hence protects the equipment from overheating. **DO NOT COVER THE OPENINGS.**
6. Make sure the voltage of the power source and adjust properly 110/220V before connecting the equipment to the power inlet.
7. Place the power cord such a way that people can not step on it. Do not place anything over the power cord.
8. Always Unplug the Power Cord before inserting any add-on card or module.
9. All cautions and warnings on the equipment should be noted.
10. Never pour any liquid into the opening that could damage or cause electrical shock.
11. If any of the following situations arises, get the equipment checked by a service personnel:
  - The power cord or plug is damaged
  - Liquid has penetrated into the equipment
  - The equipment has been exposed to moisture
  - The equipment has not work well or you can not get it work according to User's Manual.
  - The equipment has dropped and damaged
  - If the equipment has obvious sign of breakage
12. **DO NOT LEAVE THIS EQUIPMENT IN AN ENVIRONMENT UNCONDITIONED, STORAGE TEMPERATURE ABOVE 60°C (140°F), IT MAY DAMAGE THE EQUIPMENT.**



**CAUTION:** Danger of explosion if battery is incorrectly replaced. Replace only with the same or equivalent type recommended by the manufacturer.

# CONTENTS

<b>Chapter 1. Getting Started .....</b>	<b>1-1</b>
Mainboard Specification .....	1-2
Mainboard Layout .....	1-4
Quick Components Guide .....	1-5
Fuzzy Logic™ III .....	1-6
MSI Special Features .....	1-6
Live BIOS™/Live Driver™ .....	1-7
Live Monitor™ .....	1-8
D-Bracket™ (Optional) .....	1-9
S-Bracket (Optional) .....	1-11
MSI DVD (5.1 Channel) .....	1-12
<b>Chapter 2. Hardware Setup .....</b>	<b>2-1</b>
Central Processing Unit: CPU .....	2-2
CPU Installation Procedures .....	2-2
Installing the CPU Fan .....	2-3
CPU Core Speed Derivation Procedure .....	2-4
Memory .....	2-5
Introduction to DDR SDRAM .....	2-5
DIMM Module Combination .....	2-6
Installing DIMM Modules .....	2-6
Power Supply .....	2-7
ATX 20-Pin Power Connector: CONN1 .....	2-7
ATX 12V Power Connector: JPW1 .....	2-7
Back Panel .....	2-8
Mouse Connector .....	2-8
Keyboard Connector .....	2-9
USB Connectors .....	2-9
Serial Port Connectors: COM A & COM B .....	2-10
LAN (RJ-45) Jack (Optional) .....	2-10

Parallel Port Connector: LPT1 .....	2-11
Joystick/Midi Connector .....	2-12
Audio Port Connectors .....	2-12
Connectors .....	2-13
Floppy Disk Drive Connector: FDD1 .....	2-13
Hard Disk Connectors: IDE1 & IDE2 .....	2-14
Fan Power Connectors: CPUFA/SYSFA .....	2-15
IrDA Infrared Module Header: JIR1 .....	2-16
Bluetooth Connector: JBT1 (Optional) .....	2-16
Front Panel Connectors: JFP1 & JFP2 .....	2-17
Modem Connector: JMOD1 (Optional) .....	2-18
Front Panel Audio Connector: JAUD1 .....	2-19
Front USB Connectors: JUSB1 .....	2-20
CD-In Connector: JCD1 .....	2-22
D-Bracket™ Connector: JDB1 .....	2-23
S-Bracket Connector: JSP3 .....	2-24
Jumpers .....	2-25
Clear CMOS Jumper: JBAT1 .....	2-25
Slots .....	2-26
AGP (Accelerated Graphics Port) Slot .....	2-26
PCI Slots .....	2-26
CNR (Communication Network Riser) Slot .....	2-26
PCI Interrupt Request Routing .....	2-27
<b>Chapter 3. BIOS Setup .....</b>	<b>3-1</b>
Entering Setup .....	3-2
Control Keys .....	3-2
Getting Help .....	3-3
The Main Menu .....	3-4
Standard CMOS Features .....	3-6
Advanced BIOS Features .....	3-8

Advanced Chipset Features .....	3-12
Power Management Features .....	3-14
PNP/PCI Configurations .....	3-18
Integrated Peripherals .....	3-21
PC Health Status .....	3-25
Frequency/Voltage Control .....	3-26
Set Supervisor/User Password .....	3-28
Load High Performance/BIOS Setup Defaults .....	3-29
<b>Appendix A: Using 4- or 6-Channel Audio Function .....</b>	<b>A-1</b>
Installing the Audio Driver .....	A-2
Installation for Windows 98SE/ME/2000/XP .....	A-2
Using 4- or 6-Channel Audio Function .....	A-4
Attaching Speakers .....	A-4
Selecting 4- or 6-Channel Setting .....	A-9
Testing the Connected Speakers .....	A-11
Testing Each Speaker: .....	A-11
Playing KaraOK .....	A-12
Playing KaraOK: .....	A-12
<b>Glossary .....</b>	<b>G-1</b>

---

# Getting Started

# 1

Thank you for purchasing 645E Max2 (MS-6567) series ATX motherboard. The 645E Max2 (MS-6567) series is a superior computer mainboard based on **SiS 645DX & 962L** chipsets for optimal system efficiency. Designed to fit the advanced Intel® Pentium® 4 processors in the 478 pin package, the motherboard provides a high performance and professional desktop platform solution.

## TOPICS

<i>Mainboard Specification</i>	<i>1-2</i>
<i>Mainboard Layout</i>	<i>1-4</i>
<i>Quick Components Guide</i>	<i>1-5</i>
<i>MSI Special Features</i>	<i>1-6</i>



## Mainboard Specification

---

### CPU

- Supports Socket 478 for P4 processors (Willimite 478 and Northwood 478)
- FSB @400/533 MHz (100/133 MHz QDR)
- Supports 1.3GHz, 1.4GHz, ... 2.4GHz and up

### Chipset

- SiS 645DX chipset (702 BGA)
  - Supports 64-bit P4 processors at 533MHz
  - Supports 32-bit AGP 4x/2x slot
  - Supports 64-bit high performance DDR333 / DDR266 memory controller
  - Supports bi-directional 16-bit data bus with 533MHz bandwidth MuTIOL
- SiS 962L chipset (371 BGA)
  - Supports Dual-IDE ATA 66/100/133
  - AC'97 link controller
  - Low pin count interface for SIO
  - Supports USB 2.0

### Main Memory

- Three 184-pin DDR DIMM sockets
- Maximum memory size up to 3GB without ECC

### Slots

- One AGP (2x/4x) universal slot
- Five 32-bit Master PCI slots (PCI v2.2)
- One CNR (Communication Network Riser) slot

### On-Board IDE

- Dual IDE controllers integrated in SiS 962L
- Supports PIO, Bus Master, Ultra DMA 66/100/133 operation

### On-Board Peripherals

- External:
  - PS2 Keyboard + PS2 Mouse
  - USB x 2
  - Parallel + Serial 2
  - Game port + Audio (Mic-in, Line-in, Line-out)
  - RJ45 (LAN)

● Internal:

- Front Panel (2 x 5) w/ Intel pin definition
- Front USB (2 x 5) w/ Intel pin definition
- Front Audio (2 x 5) w/ Intel pin definition
- Front IR (2 x 5) w/ Intel pin definition
- IDE x 2, Floppy, ATX power connector
- CPU Fan, System Fan, Audio (CD-in)

**Audio**

- AC97 link controller integrated in SiS 962L
- Dual layout 2-channel and 6-channel software codec
  - Compliance w/ AC97 v2.2 spec.
  - Meets PC2001 audio performance requirement
  - Supports SPDIF I/O

**BIOS**

- 2Mb AMI BIOS w/ PnP, ACPI, SMBIOS 2.3, Green and Boot Block
- Provides DMI2.0, WfM2.0, WOR and SMBus for system management.

**Dimension**

- ATX Form Factor: 30.5 cm (L) x 23 cm (W)

**Mounting**

- 6 mounting holes

**Others**

- Vcore adjustable
- STR support
- PC2001 compliant
- Supports S-Bracket (optional)
- Supports 533MHz FSB
- Supports LAN (optional)

# Mainboard Layout

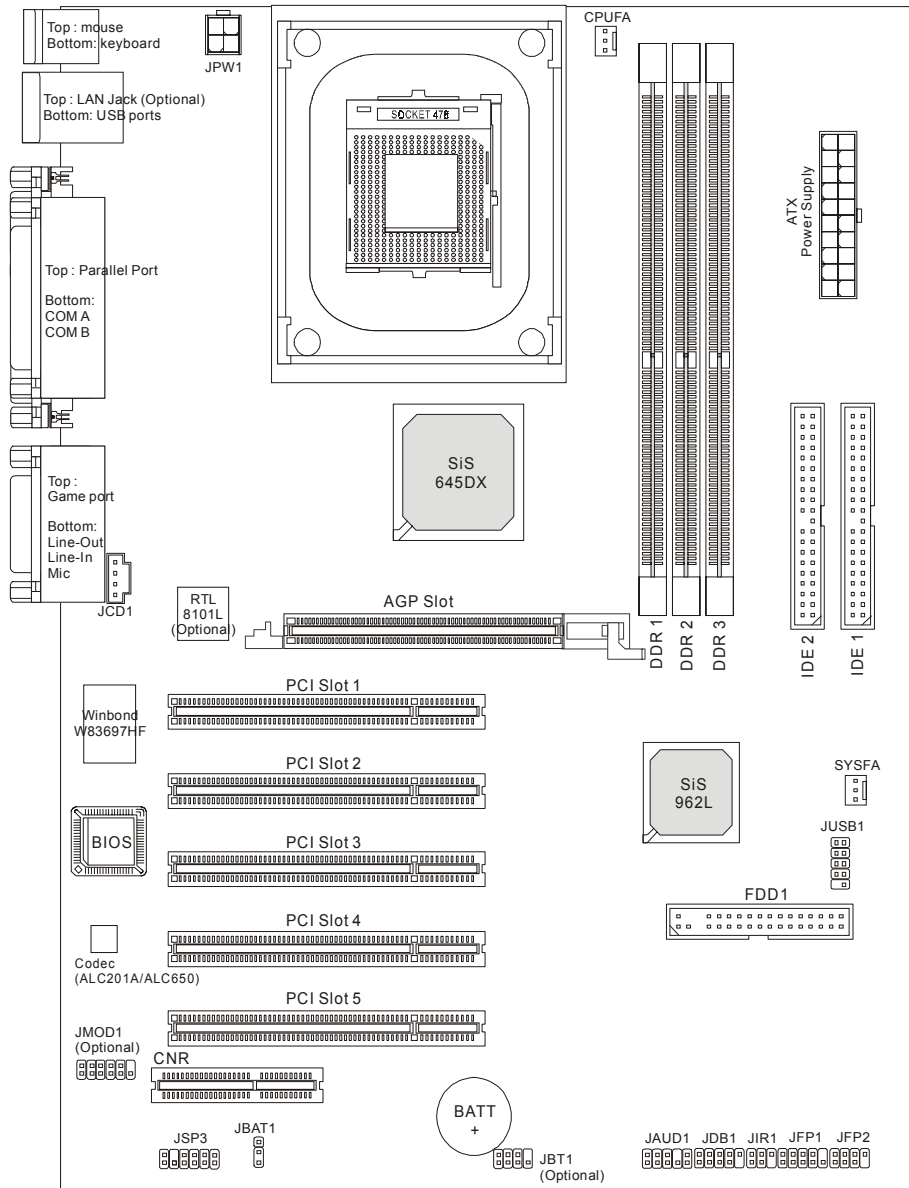

**645E Max2 (MS-6567) series ATX Mainboard**

## Quick Components Guide

---

Component	Function	Reference
DDR1~3	Installing DDR SDRAM modules	See p. 2-5~2-6
Socket 478	Installing CPU	See p. 2-2~2-4
CPUFA	Connecting to CPUFAN	See p. 2-16
SYSFA	Connecting to SYSTEM FAN	See p. 2-16
ATX Power Supply	Installing power supply	See p. 2-7
JPW1	Connecting to 12V power connector	See p. 2-7
IDE1 & IDE2	Connecting to IDE hard disk drive	See p.2-14
IDE3 & IDE4	Connecting to IDE RAID HDD	See p.2-15
FDD1	Connecting to floppy disk drive	See p.2-13
JUSB1/3/4	Connecting to USB interfaces	See p. 2-21~2-22
PCI Slot 1~5	Installing expansion cards	See p. 2-27
AGP Slot	Installing AGP cards	See p. 2-27
CNR Slot	Installing CNR cards	See p. 2-27
JMOD1	Connecting to modem module	See p. 2-19
JBAT1	Clearing CMOS data	See p. 2-26
JFP1/2	Connecting to case	See p. 2-18
JIR1	Connecting to IR module	See p. 2-17
JAUD1	Connecting to audio connector	See p. 2-20
JDB1	Connecting to D-Bracket™ (optional)	See p. 2-24
JSP3	Connecting to SPDIF interface (optional S-Bracket)	See p. 2-25
JCD1	Connecting to CD-ROM audio connector	See p. 2-23

## MSI Special Features

---

### Fuzzy Logic™ III

The Fuzzy Logic™ III utility allows users to overclock the CPU FSB (Front Side Bus) frequency in the Windows environment. Select the CPU frequency you prefer and click *Go* to apply the frequency or click *Save* allowing the system to run at the specified frequency each time when the system is powered on.

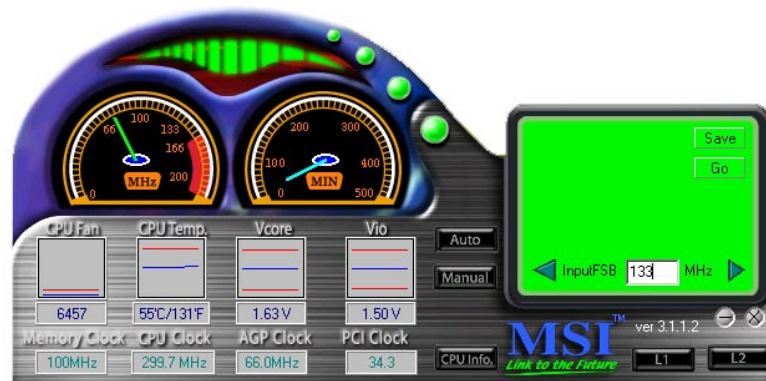

#### Features:

- Display Current System Status
  - CPU Fan
  - CPU Temp.
  - Vcore
  - Memory Clock
  - CPU Clock
  - AGP Clock
  - PCIClock
- Adjust CPU FSB Frequency

## Live BIOS™/Live Driver™

The Live BIOS™/Live Driver™ is a tool used to detect and update your BIOS/drivers online so that you don't need to search for the correct BIOS/driver version throughout the whole Web site. To use the function, you need to install the "MSI Live Update Series 2" application. After the installation, the "MSI Live Update Series 2" icon (as shown on the right) will appear on the screen.



Double click the "MSI Live Update Series 2" icon, and the following screen will appear:

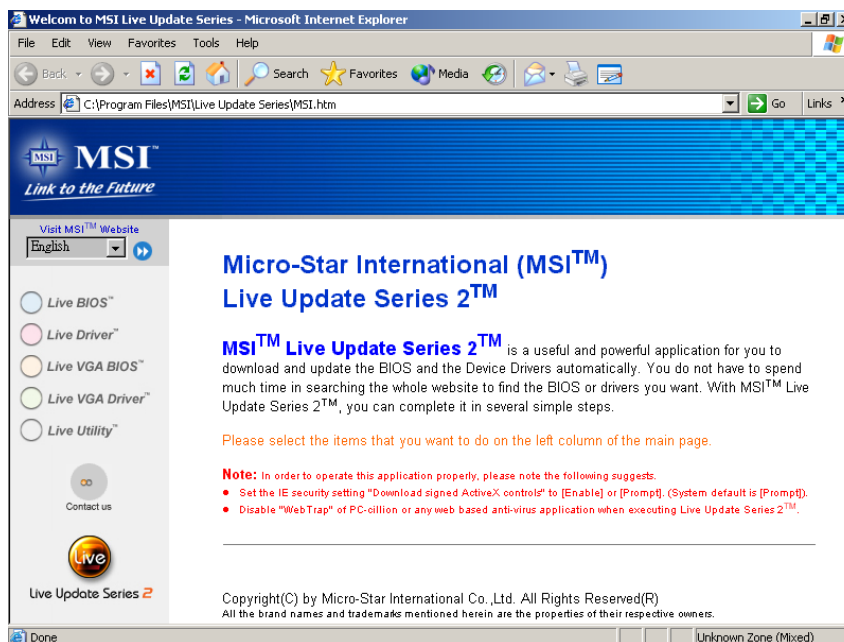

Five buttons are placed on the leftmost pane of the screen. Click the desired button to start the update process.

- **Live BIOS** – Updates the BIOS online.
- **Live Driver** – Updates the drivers online.
- **Live VGA BIOS** – Updates the VGA BIOS online.
- **Live VGA Driver** – Updates the VGA driver online.
- **Live Utility** – Updates the utilities online.

If the product you purchased does not support any of the functions listed above, a "sorry" message is displayed. For more information on the update instructions, insert the companion CD and refer to the "Live Update Series Guide" under the "Manual" Tab.

## Live Monitor™

The Live Monitor™ is a tool used to schedule the search for the latest BIOS/drivers version on the MSI Web site. To use the function, you need to install the “MSI Live Update Series 2” application. After the installation, the “MSI Live Monitor” icon (as shown on the right) will appear on the screen. Double click this icon to run the application.



Double click the “MSI Live Monitor” icon  at the lower-right corner of the taskbar, and the following dialog box will appear. You can specify how often the system will automatically search for the BIOS/drivers version, or change the LAN settings right from the dialog box.

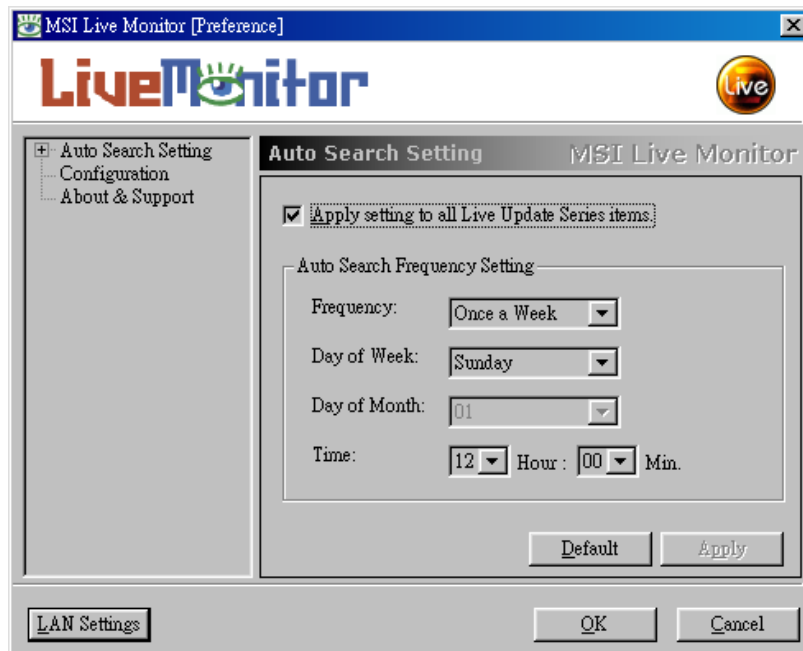

You can right-click the MSI Live Monitor icon  to perform the functions listed below:

- **Auto Search** – Searches for the BIOS/drivers version you need immediately.
- **View Last Result** – Allows you to view the last search result if there is any.
- **Preference** – Configures the Search function, including the Search schedule.
- **Exit** – Exits the Live Monitor™ application.

## D-Bracket™ (Optional)

D-Bracket™ is a USB bracket integrating four Diagnostic LEDs, which use graphic signal display to help users understand their system. The LEDs provide up to 16 combinations of signals to debug the system. The 4 LEDs can debug all problems that fail the system, such as VGA, RAM or other failures. This special feature is very useful for the overclocking users. These users can use the feature to detect if there are any problems or failures.

D-Bracket™

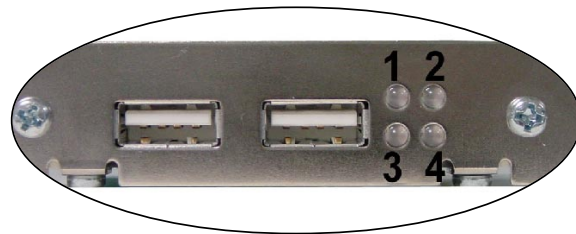









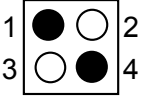

● Red      ○ Green

D-Bracket	Description
	System Power ON - The D-LED will hang here if the processor is damaged or not installed properly.
	Early Chipset Initialization
	Memory Detection Test - Testing onboard memory size. The D-LED will hang if the memory module is damaged or not installed properly.
	Decompressing BIOS image to RAM for fast booting.
	Initializing Keyboard Controller.
	Testing VGA BIOS - This will start writing VGA sign-on message to the screen.



## Chapter 1

D-Bracket	Description
	<p>Processor Initialization</p> <p>- This will show information regarding the processor (like brand name, system bus, etc...)</p>
	<p>Testing RTC (Real Time Clock)</p>
	<p>Initializing Video Interface</p> <p>- This will start detecting CPU clock, checking type of video onboard. Then, detect and initialize the video adapter.</p>
	<p>BIOS Sign On</p> <p>- This will start showing information about logo, processor brand name, etc....</p>
	<p>Testing Base and Extended Memory</p> <p>- Testing base memory from 240K to 640K and extended memory above 1MB using various patterns.</p>
	<p>Assign Resources to all ISA.</p>
	<p>Initializing Hard Drive Controller</p> <p>- This will initialize IDE drive and controller.</p>
	<p>Initializing Floppy Drive Controller</p> <p>- This will initializing Floppy Drive and controller.</p>
	<p>Boot Attempt</p> <p>- This will set low stack and boot via INT 19h.</p>
	<p>Operating System Booting</p>

## S-Bracket (Optional)

S-Bracket is a bracket which provides 2 SPDIF jacks for digital audio transmission and 2 analog Line-Out connectors for additional 4-channel analog audio output. With the S-Bracket, your system will be able to perform 6-channel audio operation for wonderful surround sound effect, or connect to Sony & Philips Digital Interface (SPDIF) speakers for audio transmission with better quality.

The S-Bracket offers two types of SPDIF connectors: one for optical fiber and the other for coaxial connection. Select the appropriate one to meet your own need. For more information on S-Bracket, refer to *Appendix A: Using 4- or 6-Channel Audio Function*.

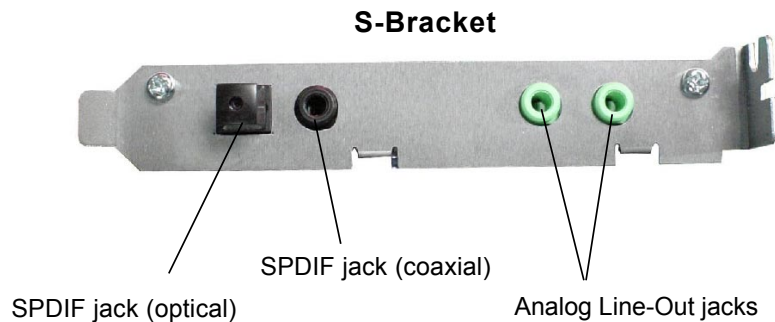

## MSI DVD (5.1 Channel)

The motherboard comes with MSI DVD application which supports 5.1 channel (6-channel audio) operation. The accompanying MSI DVD is a convenient tool to meet increasing demands for home entertainment.

 **Note:** MSI DVD supports Dolby Digital format only. To view DTS-formatted video, you should convert it to Dolby Digital format first.



To play DVD with 6-channel audio output, you must configure both the MSI DVD application and the audio codec's software utility. Otherwise, the 6-channel audio function will not work properly. For information on how to select 6-channel mode in the audio software utility, refer to *Appendix. Using 4- or 6-Channel Audio Function*.

Follow the procedures below to enable 6-channel support with MSI DVD:

1. Click on this button  from the control panel of MSI DVD.
2. Click the **Audio** tab.
3. Select **6 speaker mode (5.1 channel)**.

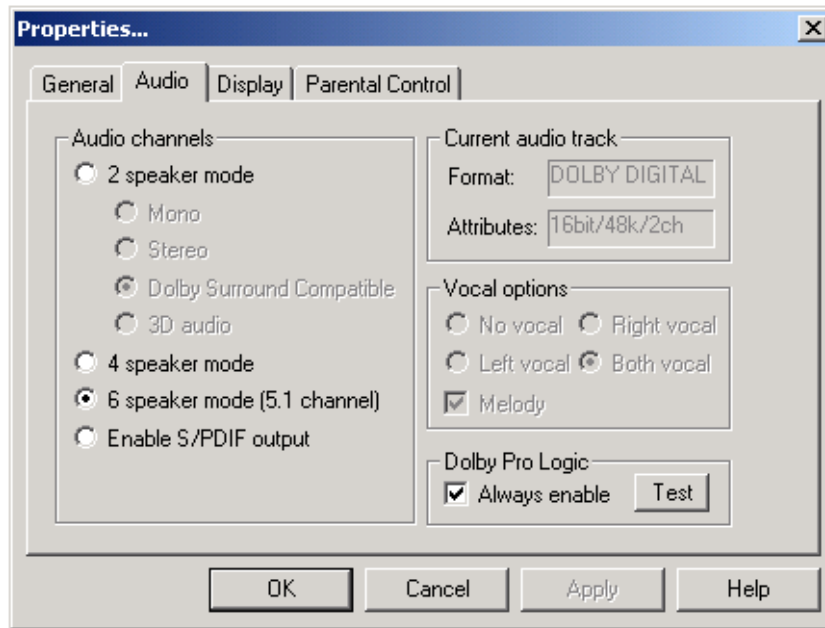

4. Click **OK**.

For more information about MSI DVD, you can refer to the online help coming with the application.

To enter the online help:

1. Click on the icon  at the bottom-right corner of the control panel.
2. The following window appears.

Click here

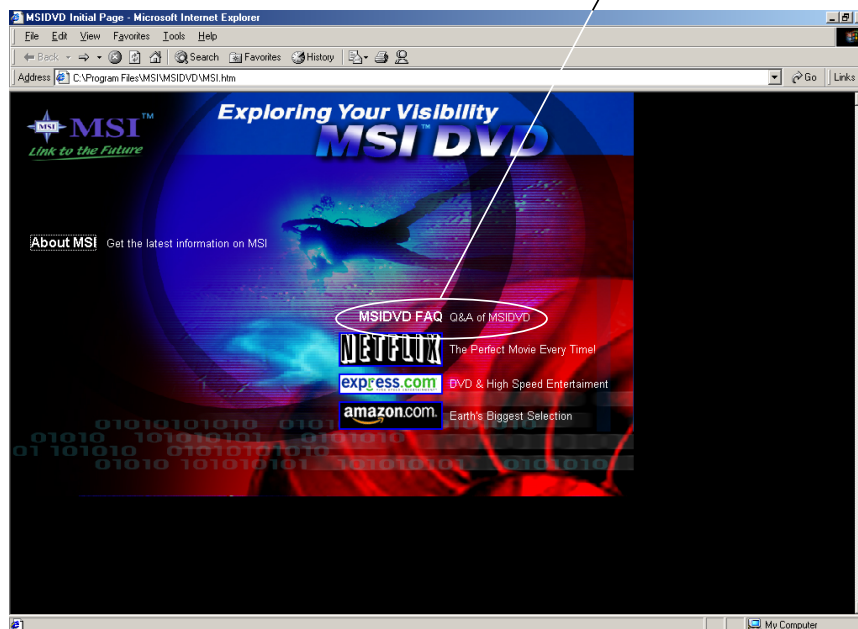

3. Click **MSIDVD FAQ**.

---

# Hardware Setup 2

This chapter provides you with the information about hardware setup procedures. While doing the installation, be careful in holding the components and follow the installation procedures. For some components, if you install in the wrong orientation, the components will not work properly.

Use a grounded wrist strap before handling computer components. Static electricity may damage the components.

## TOPICS

<i>Central Processing Unit: CPU</i>	2-2
<i>Memory</i>	2-5
<i>Power Supply</i>	2-7
<i>Back Panel</i>	2-8
<i>Connectors</i>	2-13
<i>Jumpers</i>	2-25
<i>Slots</i>	2-27

## Central Processing Unit: CPU

---

The mainboard supports Intel® Pentium® 4 processor in the 478 pin package. The mainboard uses a CPU socket called PGA478 for easy CPU installation. When you are installing the CPU, **make sure the CPU has a heat sink and a cooling fan attached on the top to prevent overheating.** If you do not find the heat sink and cooling fan, contact your dealer to purchase and install them before turning on the computer.

### CPU Installation Procedures

1. Pull the lever sideways away from the socket. Then, raise the lever up to a 90-degree angle.
2. Look for the gold arrow. The gold arrow should point towards the lever pivot. The CPU will only fit in the correct orientation.
3. Hold the CPU down firmly, and then close the lever to complete the installation.

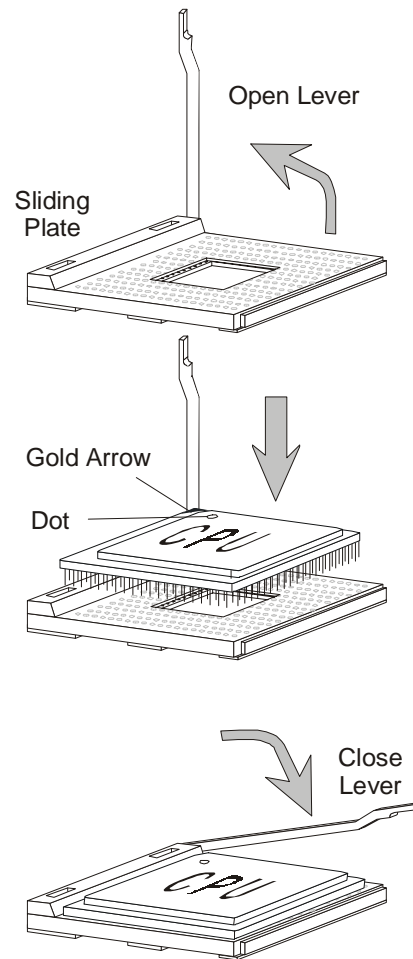

**WARNING!**

*Overheating will seriously damage the CPU and system, always make sure the cooling fan can work properly to protect the CPU from overheating.*

## **Installing the CPU Fan**

As processor technology pushes to faster speeds and higher performance, thermal management becomes increasingly important. To dissipate heat, you need to attach the CPU cooling fan and heatsink on top of the CPU. Follow the instructions below to install the Heatsink/Fan:

1. Locate the CPU and its retention mechanism on the motherboard.
2. Position the heatsink onto the retention mechanism.

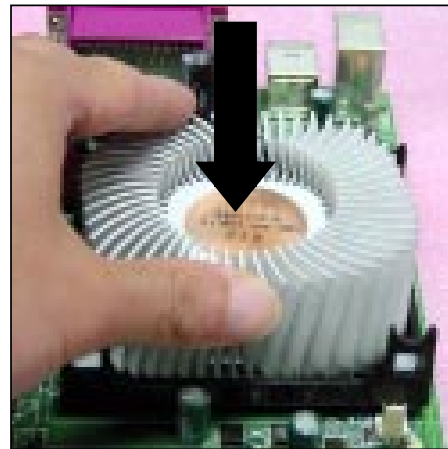
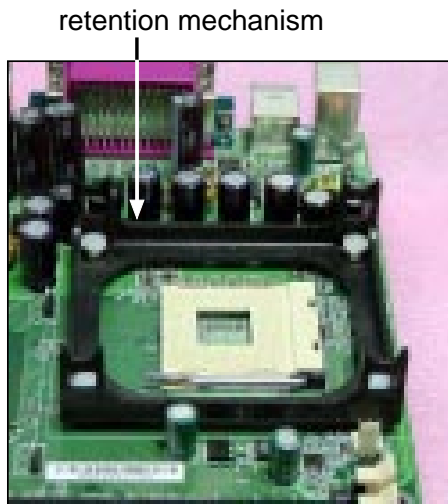

3. Mount the fan on top of the heatsink. Press down the fan until its four clips get wedged in the holes of the retention mechanism.
4. Press the two levers down to fasten the fan. Each lever can be pressed down in only ONE direction.

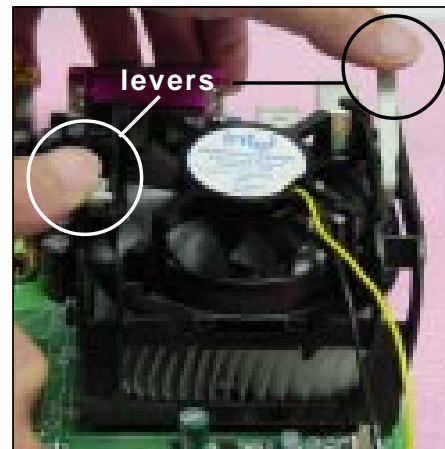
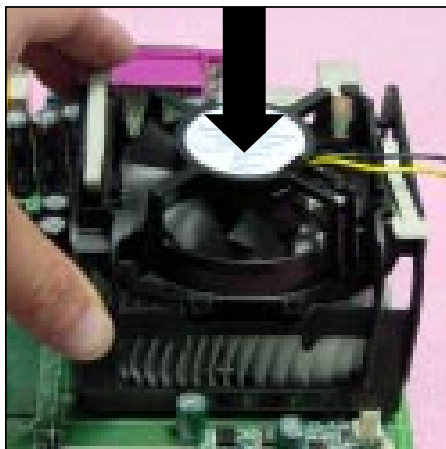

## Chapter 2

5. Connect the fan power cable from the mounted fan to the 3-pin fan power connector on the board.

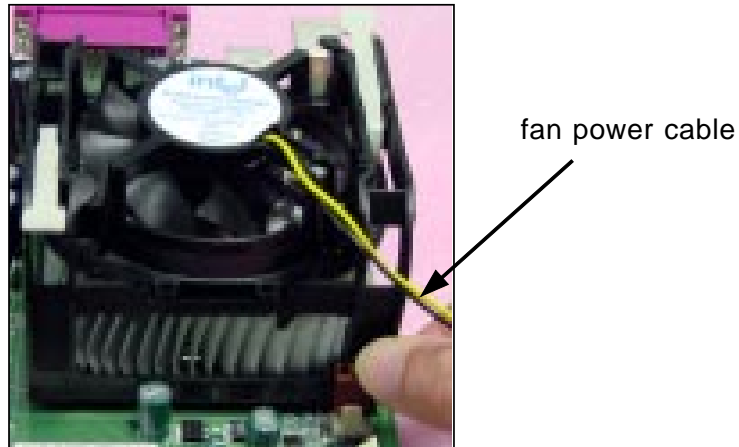

---

### CPU Core Speed Derivation Procedure

**If** CPU Clock = 100MHz  
Core/Bus ratio = 14  
**then** CPU core speed = Host Clock x Core/Bus ratio  
= 100MHz x 14  
= 1.4GHz



**WARNING!**

#### ***Overclocking***

*This motherboard is designed to support overclocking. However, please make sure your components are able to tolerate such abnormal setting, while doing overclocking. Any attempt to operate beyond product specifications is not recommended. We do not guarantee the damages or risks caused by inadequate operation or beyond product specifications.*



## Memory

---

The mainboard provides 3 sockets for 184-pin DDR SDRAM DIMM (Double In-Line Memory Module) modules and supports the memory size up to 3GB. You can install PC2700/DDR333, PC2100/DDR266 or PC1600/DDR200 DRAM modules on the DDR DIMM slots (DIMM 1~3).

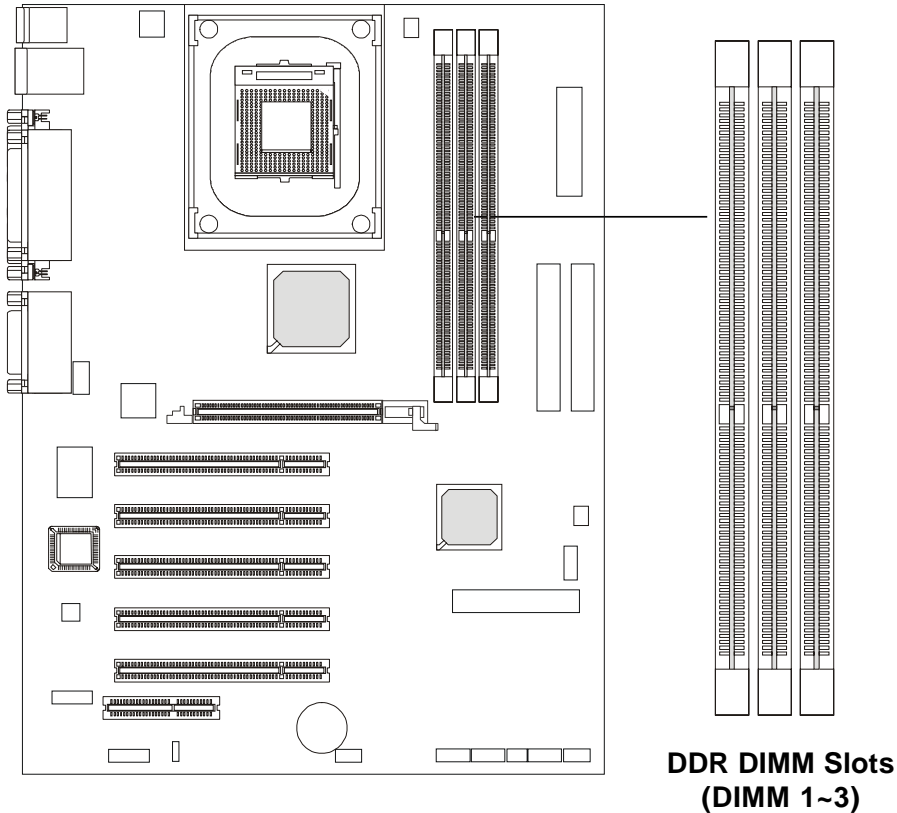

### Introduction to DDR SDRAM

DDR (Double Data Rate) SDRAM is similar to conventional SDRAM, but doubles the rate by transferring data twice per cycle. It uses 2.5 volts as opposed to 3.3 volts used in SDR SDRAM, and requires 184-pin DIMM modules rather than 168-pin DIMM modules used by SDR SDRAM. High memory bandwidth makes DDR an ideal solution for high performance PC, workstations and servers.

## Chapter 2

### DIMM Module Combination

Install at least one DIMM module on the slots. Memory modules can be installed on the slots in any order. You can install either single- or double-sided modules to meet your own needs.

Memory modules can be installed in any combination as follows:

Slot	Memory Module	Total Memory
DIMM 1 (Bank 0 & 1)	S/D	64MB~1GB
DIMM 2 (Bank 2 & 3)	S/D	64MB~1GB
DIMM 3 (Bank 4 & 5)	S/D	64MB~1GB
<b>Maximum System Memory Supported</b>		64MB~3GB

**S: Single Side**

**D: Double Side**

### Installing DIMM Modules

The DDR DIMM has only one notch on the center of the module. The module will only fit in the right orientation.

1. Insert the DIMM memory module vertically into the DIMM slot. Then push it in.

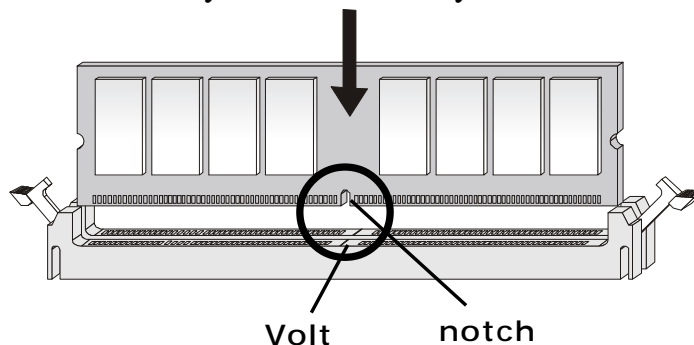

2. The plastic clip at each side of the DIMM slot will automatically close.

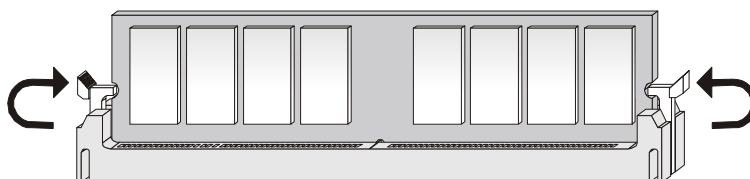

## Power Supply

The mainboard supports ATX power supply for the power system. Before inserting the power supply connector, always make sure that all components are installed properly to ensure that no damage will be caused.

### ATX 20-Pin Power Connector: CONN1

This connector allows you to connect to an ATX power supply. To connect to the ATX power supply, make sure the plug of the power supply is inserted in the proper orientation and the pins are aligned. Then push down the power supply firmly into the connector.

### ATX 12V Power Connector: JPW1

This 12V power connector is used to provide power to the CPU.

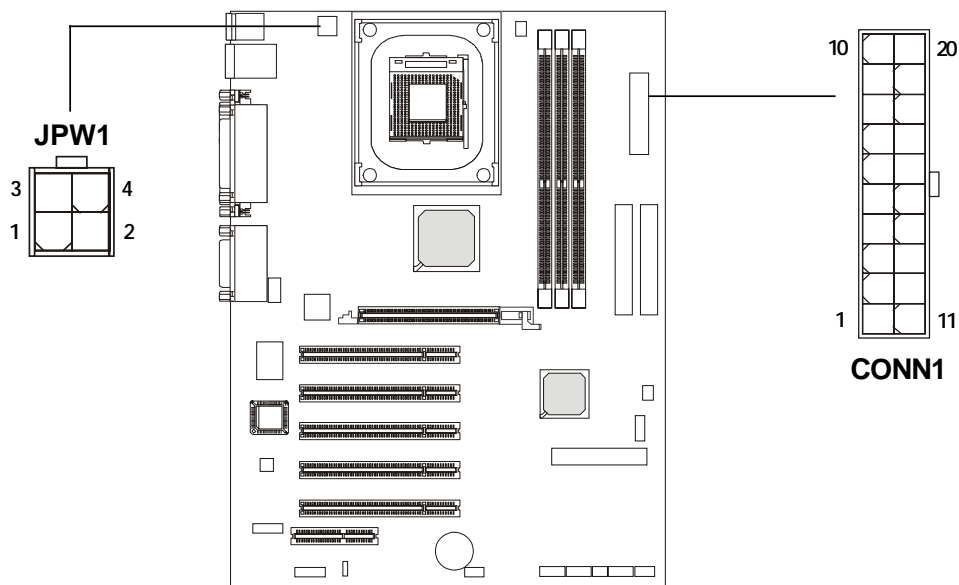

JPW1 Pin Definition

PIN	SIGNAL
1	GND
2	GND
3	12V
4	12V

CONN1 Pin Definition

PIN	SIGNAL	PIN	SIGNAL
1	3.3V	11	3.3V
2	3.3V	12	-12V
3	GND	13	GND
4	5V	14	PS_ON
5	GND	15	GND
6	5V	16	GND
7	GND	17	GND
8	PW_OK	18	-5V
9	5V_SB	19	5V
10	12V	20	5V

## Back Panel

The Back Panel provides the following connectors:

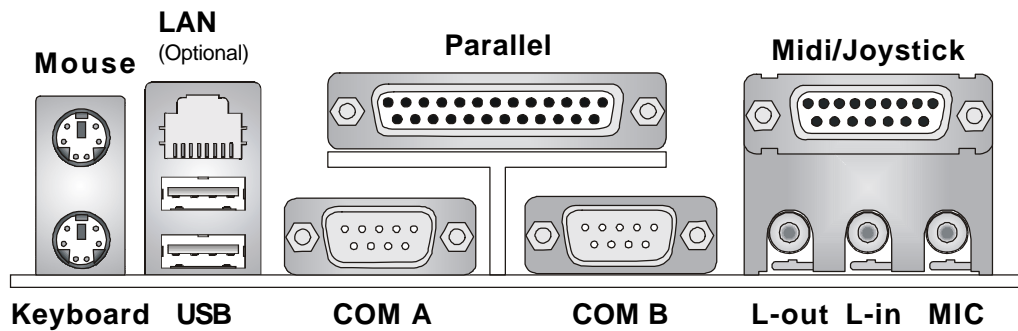

## Mouse Connector

The mainboard provides a standard PS/2<sup>®</sup> mouse mini DIN connector for attaching a PS/2<sup>®</sup> mouse. You can plug a PS/2<sup>®</sup> mouse directly into this connector. The connector location and pin assignments are as follows:

**Pin Definition**

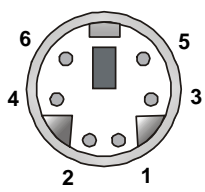

PIN	SIGNAL	DESCRIPTION
1	Mouse DATA	Mouse DATA
2	NC	No connection
3	GND	Ground
4	VCC	+5V
5	Mouse Clock	Mouse clock
6	NC	No connection

**PS/2 Mouse (6-pin Female)**

## Keyboard Connector

The mainboard provides a standard PS/2<sup>®</sup> keyboard mini DIN connector for attaching a PS/2<sup>®</sup> keyboard. You can plug a PS/2<sup>®</sup> keyboard directly into this connector.

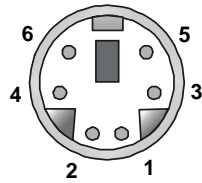

**PS/2 Keyboard (6-pin Female)**

**Pin Definition**

PIN	SIGNAL	DESCRIPTION
1	Keyboard DATA	Keyboard DATA
2	NC	No connection
3	GND	Ground
4	VCC	+5V
5	Keyboard Clock	Keyboard clock
6	NC	No connection

## USB Connectors

The mainboard provides a OHCI (Open Host Controller Interface) Universal Serial Bus root for attaching USB devices such as keyboard, mouse or other USB-compatible devices. You can plug the USB device directly into the connector.

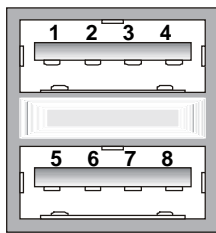

**USB Ports**

**USB Port Description**

PIN	SIGNAL	DESCRIPTION
1	VCC	+5V
2	-Data 0	Negative Data Channel 0
3	+Data0	Positive Data Channel 0
4	GND	Ground
5	VCC	+5V
6	-Data 1	Negative Data Channel 1
7	+Data 1	Positive Data Channel 1
8	GND	Ground

## Chapter 2

### Serial Port Connectors: COM A & COM B

The mainboard offers two 9-pin male DIN connectors as serial port COM A & COM B. The ports are 16550A high speed communication ports that send/receive 16 bytes FIFOs. You can attach a serial mouse or other serial devices directly to the connectors.

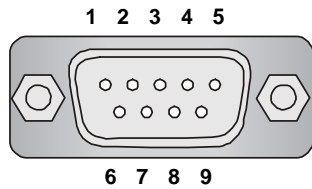

**9-Pin Male DIN Connector**

**Pin Definition**

PIN	SIGNAL	DESCRIPTION
1	DCD	Data Carry Detect
2	SIN	Serial In or Receive Data
3	SOUT	Serial Out or Transmit Data
4	DTR	Data Terminal Ready)
5	GND	Ground
6	DSR	Data Set Ready
7	RTS	Request To Send
8	CTS	Clear To Send
9	RI	Ring Indicate

---

### LAN (RJ-45) Jack (Optional)

The mainboard optionally provides one standard RJ-45 jack for connection to Local Area Network (LAN). You can connect a network cable to the LAN jack.

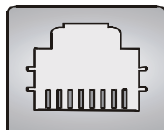

**RJ-45 LAN Jack**

**Pin Definition**

PIN	SIGNAL	DESCRIPTION
1	TDP	Transmit Differential Pair
2	TDN	Transmit Differential Pair
3	RDP	Receive Differential Pair
4	NC	Not Used
5	NC	Not Used
6	RDN	Receive Differential Pair
7	NC	Not Used
8	NC	Not Used

## Parallel Port Connector: LPT1

The mainboard provides a 25-pin female centronic connector as LPT. A parallel port is a standard printer port that supports Enhanced Parallel Port (EPP) and Extended Capabilities Parallel Port (ECP) mode.

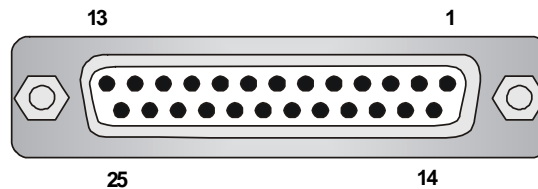

**Pin Definition**

PIN	SIGNAL	DESCRIPTION
1	STROBE	Strobe
2	DATA0	Data0
3	DATA1	Data1
4	DATA2	Data2
5	DATA3	Data3
6	DATA4	Data4
7	DATA5	Data5
8	DATA6	Data6
9	DATA7	Data7
10	ACK#	Acknowledge
11	BUSY	Busy
12	PE	Paper End
13	SELECT	Select
14	AUTO FEED#	Automatic Feed
15	ERR#	Error
16	INIT#	Initialize Printer
17	SLIN#	Select In
18	GND	Ground
19	GND	Ground
20	GND	Ground
21	GND	Ground
22	GND	Ground
23	GND	Ground
24	GND	Ground
25	GND	Ground

## Chapter 2

### Joystick/Midi Connector

You can connect a joystick or game pad to this connector.

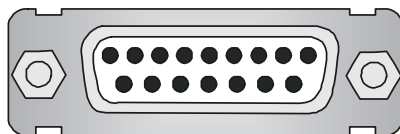

---

### Audio Port Connectors

**Line Out** is a connector for Speakers or Headphones. **Line In** is used for external CD player, Tape player, or other audio devices. **Mic** is a connector for microphones.

#### 1/8" Stereo Audio Connectors

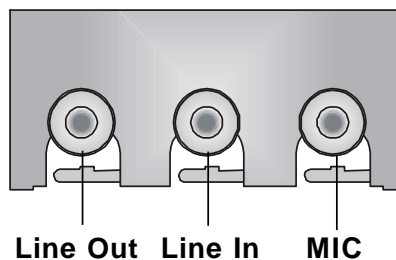

#### TIP:

*The mainboard offers support for 6-channel audio operation and can turn rear audio connectors from 2-channel to 4-/6-channel audio. For more information on the issue, refer to Appendix A: Using 4- or 6-Channel Audio Function.*



## Connectors

---

The mainboard provides connectors to connect to FDD, IDE HDD, case, modem, USB Ports, IR module, bluetooth module, SPDIF bracket and CPU/ System FAN.

### Floppy Disk Drive Connector: FDD1

The mainboard provides a standard floppy disk drive connector that supports 360K, 720K, 1.2M, 1.44M and 2.88M floppy disk types.

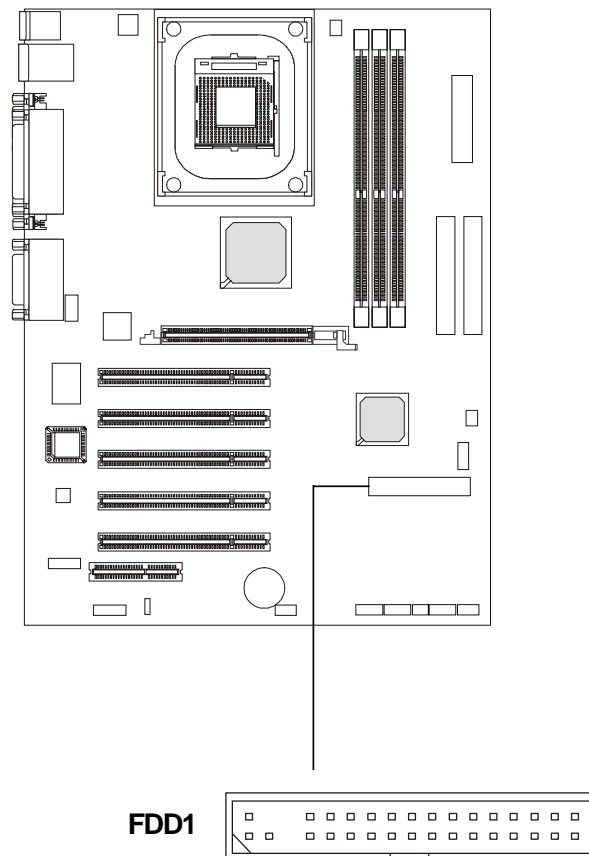

## Chapter 2

### Hard Disk Connectors: IDE1 & IDE2

The mainboard has a 32-bit Enhanced PCI IDE and Ultra DMA 33/66/100/133 controller that provides PIO mode 0~4, Bus Master, and Ultra DMA 33/66/100/133 function. You can connect up to four hard disk drives, CD-ROM, 120MB Floppy (reserved for future BIOS) and other devices. These connectors support the provided IDE hard disk cable.

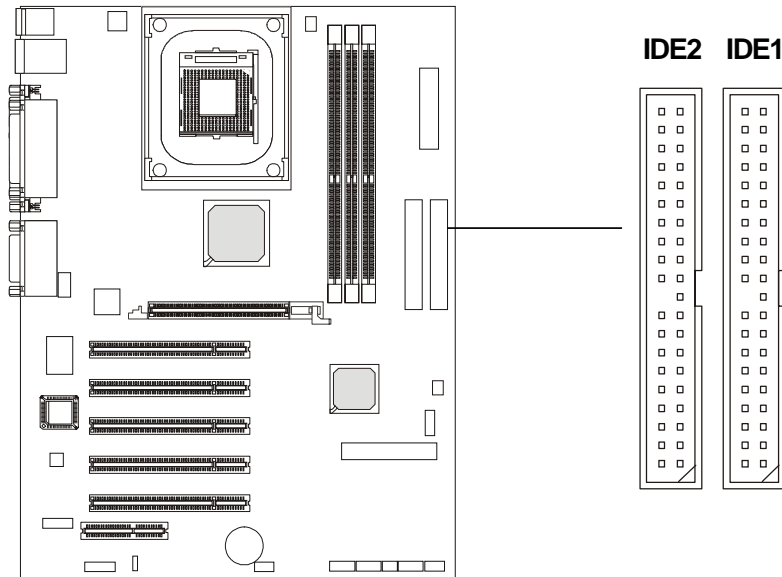

#### IDE1 (Primary IDE Connector)

The first hard drive should always be connected to IDE1. IDE1 can connect a Master and a Slave drive. You must configure second hard drive to Slave mode by setting the jumper accordingly.

#### IDE2 (Secondary IDE Connector)

IDE2 can also connect a Master and a Slave drive.



#### TIP:

*If you install two hard disks on cable, you must configure the second drive to Slave mode by setting its jumper. Refer to the hard disk documentation supplied by hard disk vendors for jumper setting instructions.*

## **Fan Power Connectors: CPUFA/SYSFA**

The CPUFA (processor fan) and SYSFA (system fan) support system cooling fan with +12V. It supports three-pin head connector. When connecting the wire to the connectors, always take note that the red wire is the positive and should be connected to the +12V, the black wire is Ground and should be connected to GND. If the mainboard has a System Hardware Monitor chipset on-board, you must use a specially designed fan with speed sensor to take advantage of the CPU fan control.

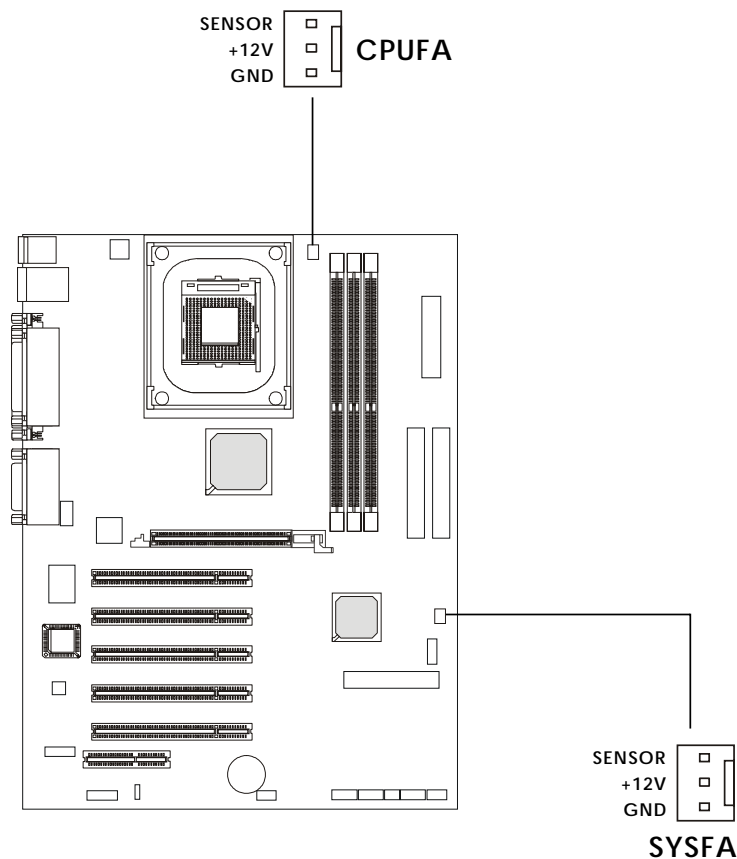

 **Note:**

- 1. Always consult the vendor for proper CPU cooling fan.*
- 2. CPU Fan supports the fan control. You can install the PC Alert utility that will automatically control the CPU Fan speed according to the actual CPU temperature.*

## Chapter 2

### IrDA Infrared Module Header: JIR1

The connector allows you to connect to IrDA Infrared module. You must configure the setting through the BIOS setup to use the IR function. JIR1 is compliant with Intel® Front Panel I/O Connectivity Design Guide.

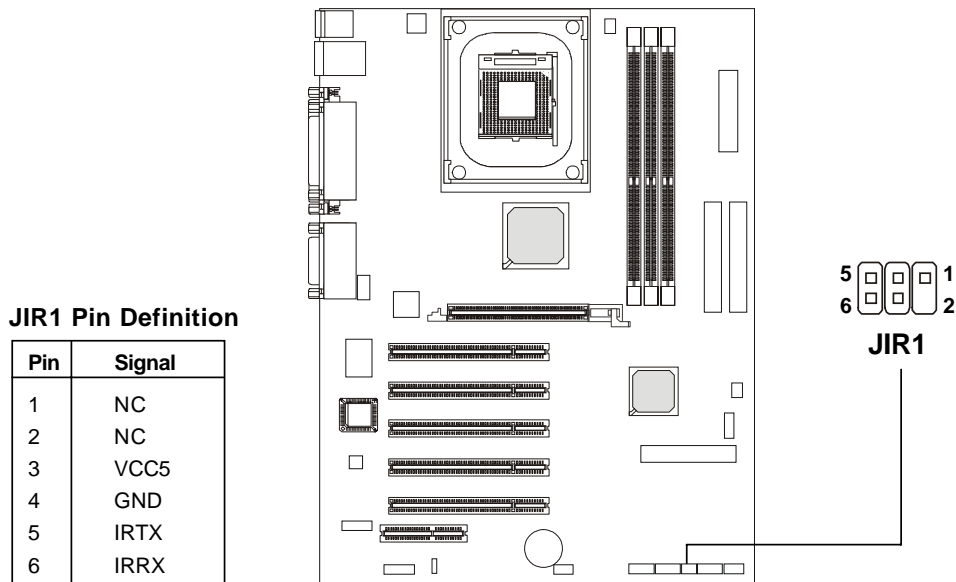

### Bluetooth Connector: JBT1 (Optional)

This connector is used to connect a bluetooth module for wireless connection.

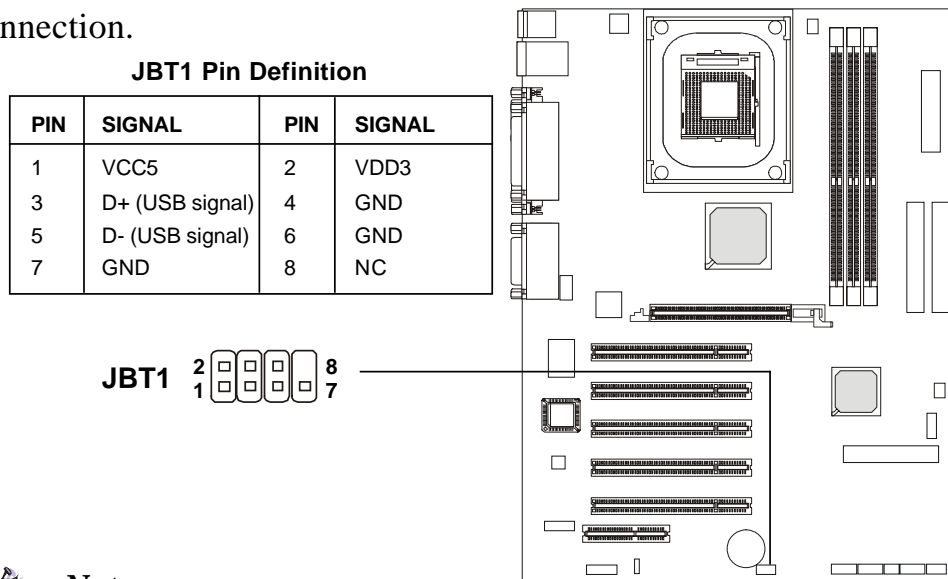

**Note:**

Because the bluetooth connector shares the USB interface with blue-colored USB2.0 connector, the bottommost USB2.0 port will not function when you attach a bluetooth module to this connector.

## Front Panel Connectors: JFP1 & JFP2

The mainboard provides two front panel connectors for electrical connection to the front panel switches and LEDs. JFP1 is compliant with Intel® Front Panel I/O Connectivity Design Guide.

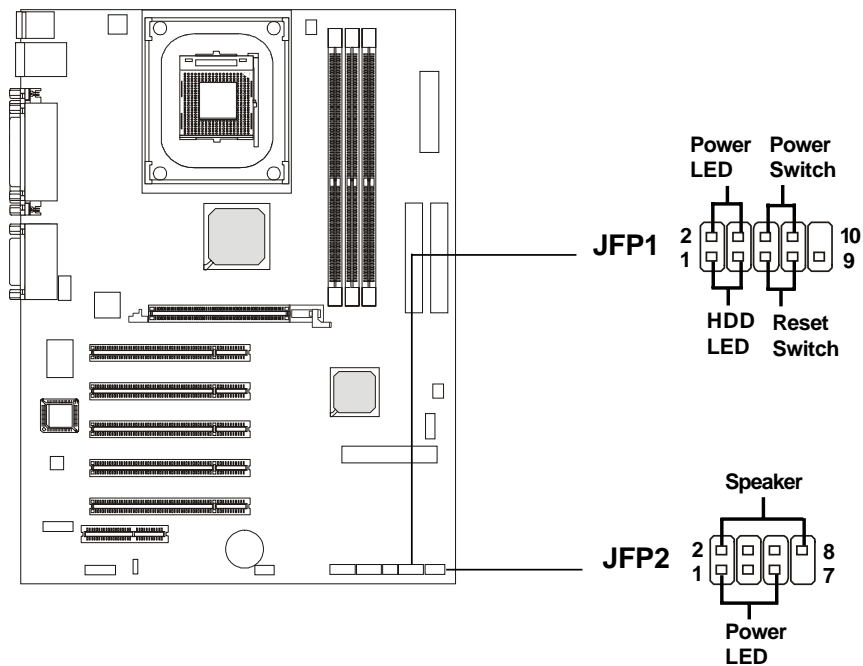

### JFP1 Pin Definition

PIN	SIGNAL	DESCRIPTION
1	HD_LED_P	Hard disk LED pull-up
2	FP_PWR/SLP	MSG LED pull-up
3	HD_LED_N	Hard disk active LED
4	FP_PWR/SLP	MSG LED pull-up
5	RST_SW_N	Reset Switch low reference pull-down to GND
6	PWR_SW_P	Power Switch high reference pull-up
7	RST_SW_P	Reset Switch high reference pull-up
8	PWR_SW_N	Power Switch low reference pull-down to GND
9	RSVD_DNU	Reserved. Do not use.

### JFP2 Pin Definition

PIN	SIGNAL	PIN	SIGNAL
1	GND	2	SPK-
3	SLED	4	BUZ+
5	PLED	6	BUZ-
7	NC	8	SPK+

## Chapter 2

### Modem Connector: JMOD1 (Optional)

This connector is connected to an optional modem module. The modem module functions in the same way as a modem, which allows users to connect to the internet via the telephone line.

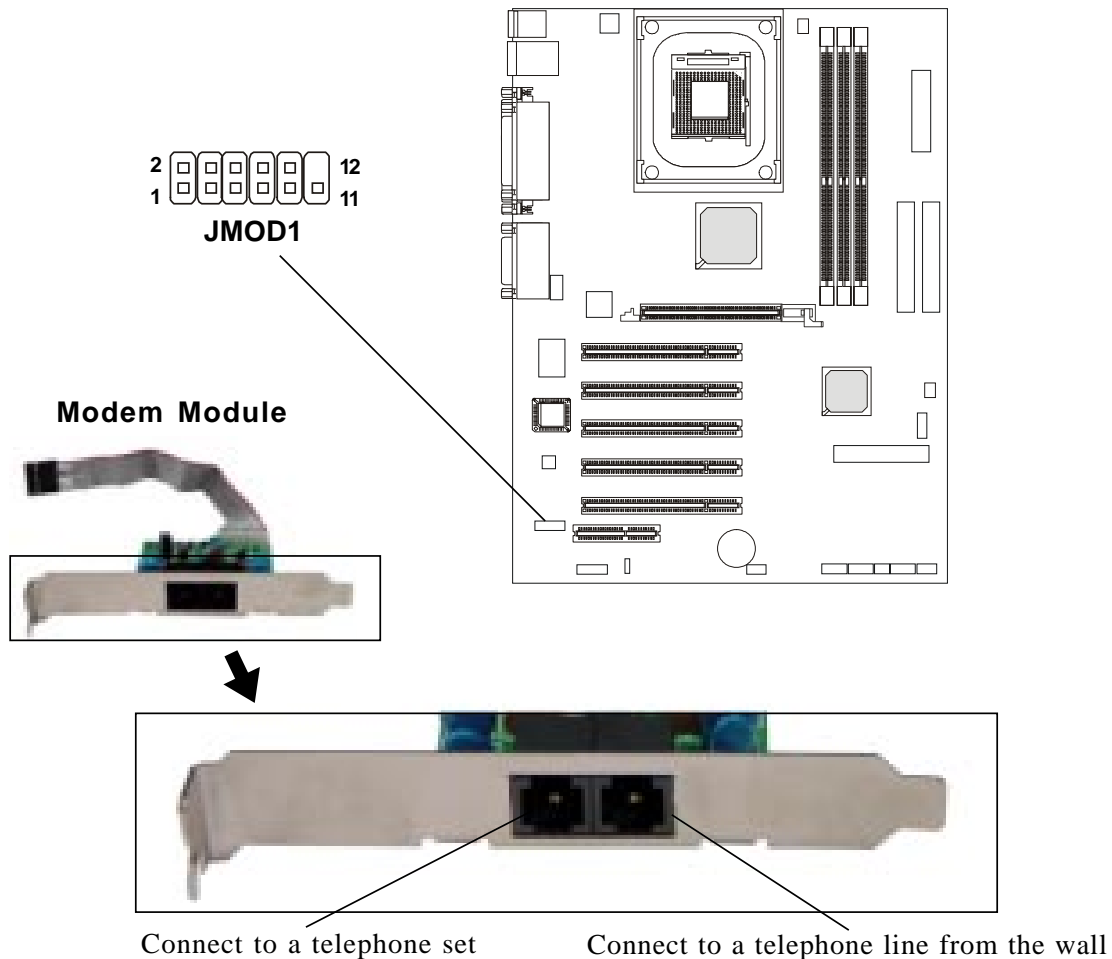

**JMOD1 Pin Definition**

PIN	SIGNAL	DESCRIPTION
1	BIT_CLK (to LAN controller)	Serial port bit clock output/input
2	SYNC (from LAN controller)	Frame Sync input
3	RESET (from LAN controller)	Reset input (active low)
4	SDATA_OUT (from LAN controller)	Serial port data input
5	SDATA_IN (to LAN controller)	Serial port data output
6	Ground (from M/B)	Connect to System Digital Ground
7	Ground (from M/B)	Connect to System Digital Ground
8	Aout (to M/B)	Analog speaker output
9	+3.3Vaux (from M/B)	+3.3V Vaux power input
10	Ground (from M/B)	Connect to System Digital Ground
11	+3.3Vaux (from M/B)	+3.3V Vaux power input
12	PIN REMOVE	PIN REMOVE

## Front Panel Audio Connector: JAUD1

The JAUD1 front panel audio connector allows you to connect to the front panel audio and is compliant with Intel® Front Panel I/O Connectivity Design Guide.

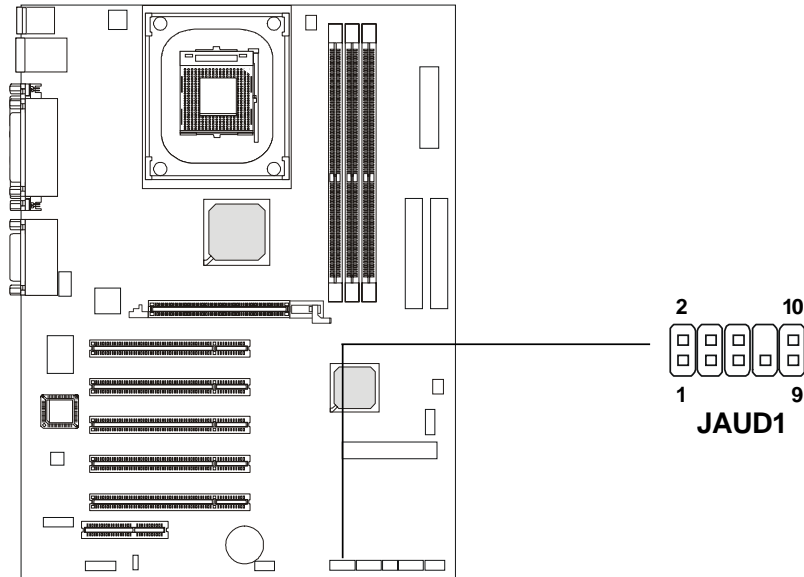

### Pin Definition

PIN	SIGNAL	DESCRIPTION
1	AUD_MIC	Front panel microphone input signal
2	AUD_GND	Ground used by analog audio circuits
3	AUD_MIC_BIAS	Microphone power
4	AUD_VCC	Filtered +5V used by analog audio circuits
5	AUD_FPOUT_R	Right channel audio signal to front panel
6	AUD_RET_R	Right channel audio signal return from front panel
7	HP_ON	Reserved for future use to control headphone amplifier
8	KEY	No pin
9	AUD_FPOUT_L	Left channel audio signal to front panel
10	AUD_RET_L	Left channel audio signal return from front panel



### Note:

If you don't want to connect to the front audio header, pins 5 & 6, 9 & 10 have to be jumpered in order to have signal output directed to the rear audio ports. Otherwise, the Line-Out connector on the back panel will not function.

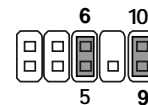

## Chapter 2

### Front USB Connectors: JUSB1

Depending on the model you have purchased, your mainboard could provide ONE USB (Universal Serial Bus) pin header that allow you to connect optional USB ports for front panel.

#### ● **USB 1.1:**

The 645E Max2 series mainboard comes with one standard USB 2.0 pin header *JUSB1* that is compliant to Intel® I/O Connectivity Design Guide. USB 2.0 technology increases data transfer rate up to a maximum throughput of 480Mbps, which is 40 times faster than USB 1.1, and is ideal for connecting high-speed USB interface peripherals such as **USB HDD, digital cameras, MP3 players, printers, modems and the like**. It is not recommended to connect low-speed USB legacy keyboard and mouse to the USB 2.0 ports. You should connect the USB legacy devices to the USB rear ports.

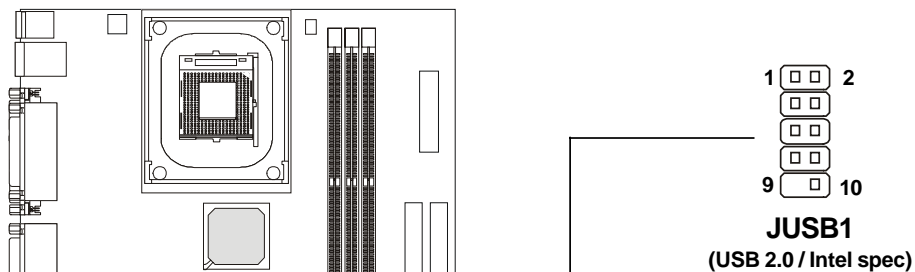

**JUSB1 Pin Definition**

Pin	Description	Pin	Description
1	USBPWR	2	USBPWR
3	USBP2-	4	USBP3-
5	USBP2+	6	USBP3+
7	GND	8	GND
9	NC	10	USBOC



### To Attach the Optional USB 2.0 Ports:

1. Take out the USB 2.0 bracket
2. Locate the JUSB3 and JUSB4 pin headers on the motherboard.
3. Connect the USB cables from USB 2.0 bracket to the JUSB3 and JUSB4 pin headers separately. *The blue connector of the USB bracket should be attached to the blue pin header on the board, and the yellow connector to the yellow pin header on the board.*

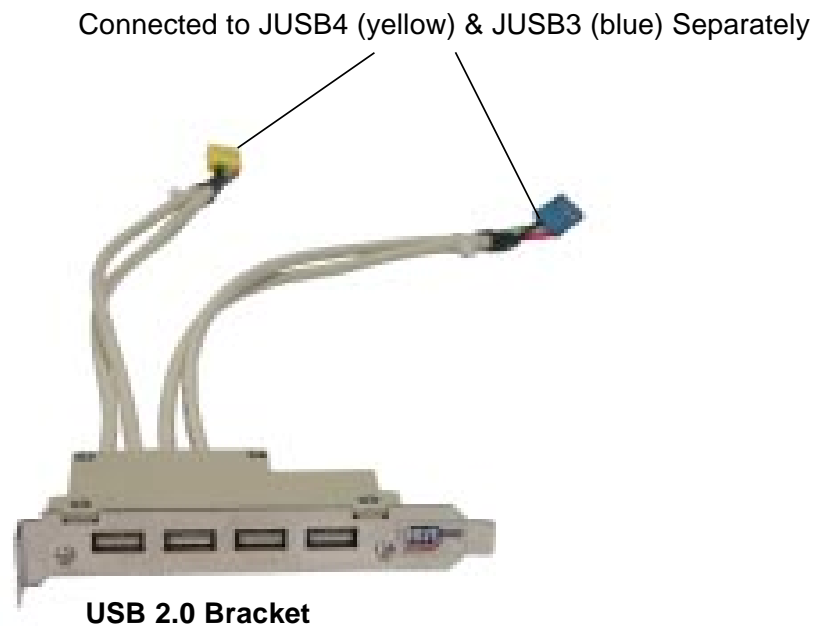

4. Place the USB 2.0 bracket into the appropriate slot of the system case.



**Note:** *The USB 2.0 controller is backwards compatible with USB 1.1 spec. To use the USB 2.0 ports, you still need to install USB 2.0 driver, which is supplied by Microsoft for Windows® 2000 and XP. If you have any problems regarding USB 2.0 driver, please visit Microsoft website for more information.*

## Chapter 2

### CD-In Connector: JCD1

The connector is for CD-ROM audio connector.

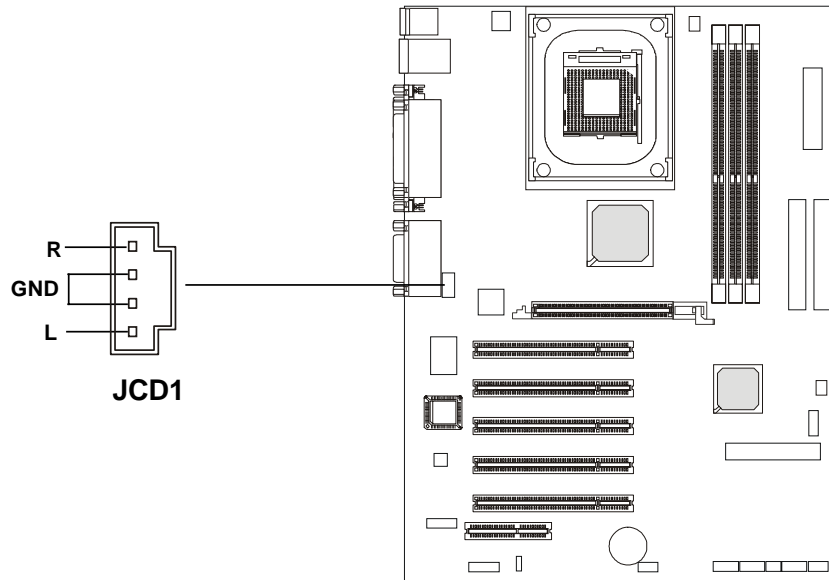

## D-Bracket™ Connector: JDB1

The mainboard comes with a JDB1 connector for you to connect to D-Bracket™. D-Bracket™ is a USB Bracket integrating four LEDs and allows users to identify system problem through 16 various combinations of LED signals. For definitions of 16 signal combinations, please refer to *D-Bracket™ (Optional)* in Chapter 1.

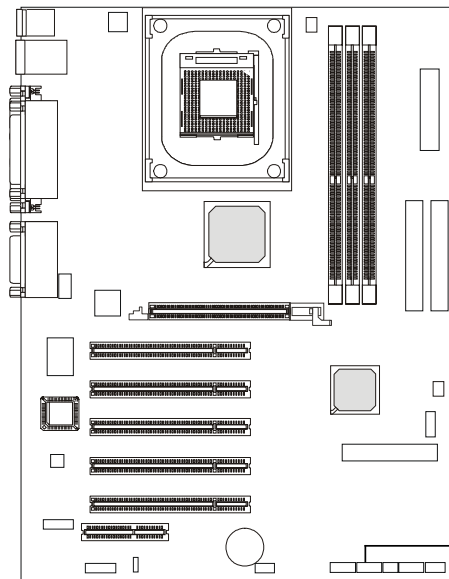

JDB1 Pin Definition

Pin	Signal
1	DBG1 (high for green color)
2	DBR1 (high for red color)
3	DBG2 (high for green color)
4	DBR2 (high for red color)
5	DBG3 (high for green color)
6	DBR3 (high for red color)
7	DBG4 (high for green color)
8	DBR4 (high for red color)
9	Key
10	NC

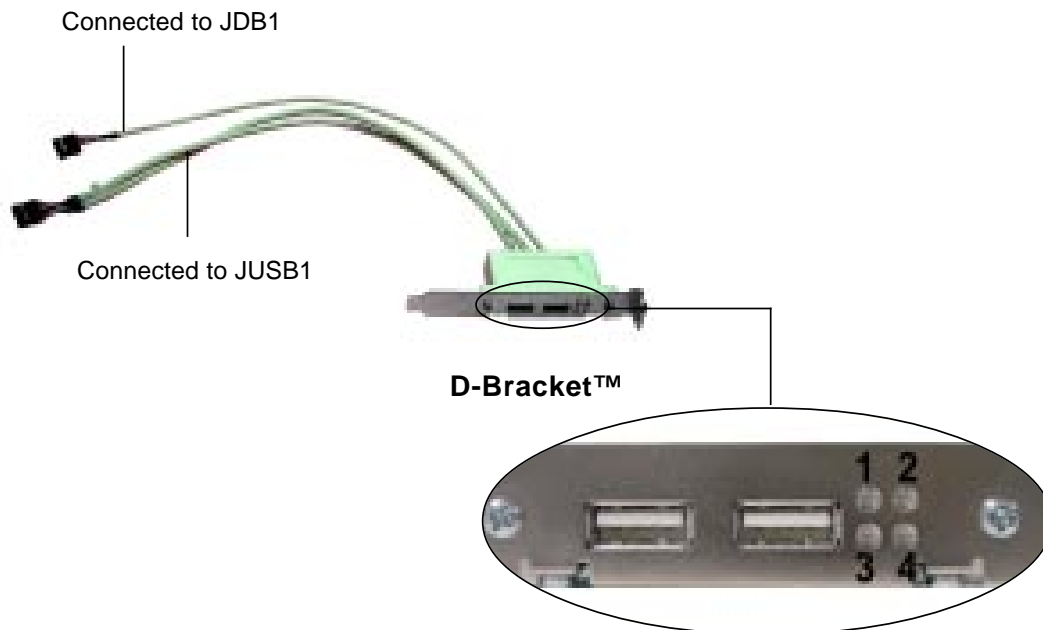
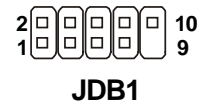

## S-Bracket Connector: JSP3

The connector allows you to connect a S-Bracket for Sony & Philips Digital Interface (SPDIF). The S-Bracket offers 2 SPDIF jacks for digital audio transmission (one for optical fiber connection and the other for coaxial), and 2 analog Line-Out jacks for 4-channel audio output.

To attach the fiber-optic cable to optical SPDIF jack, you need to remove the plug from the jack first. The two SPDIF jacks support *SPDIF output* only. For more information on the S-Bracket, refer to *Appendix A: Using 4- or 6-Channel Audio Function*.

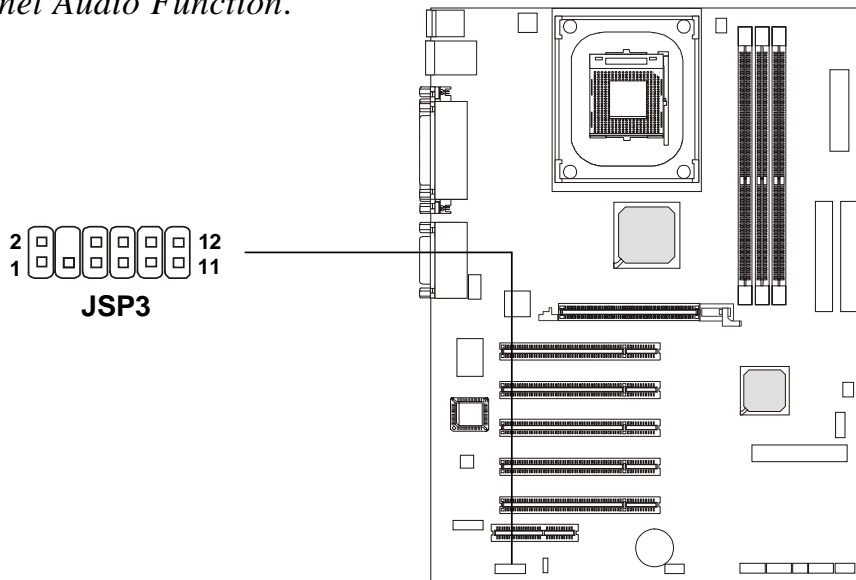

JSP3 Pin Definition

PIN	SIGNAL	DESCRIPTION	PIN	SIGNAL	DESCRIPTION
1	VCC5	VCC 5V	2	VDD3	VDD 3.3V
3	SPDFO	S/PDIF output	4	(No Pin)	Key
5	GND	Ground	6	SPDFI	S/PDIF input
7	LFE-OUT	Audio bass output	8	SOUT-R	Audio right surrounding output
9	GET-OUT	Audio center output	10	SOUT-L	Audio left surrounding output
11	GND	Ground	12	GND	Ground

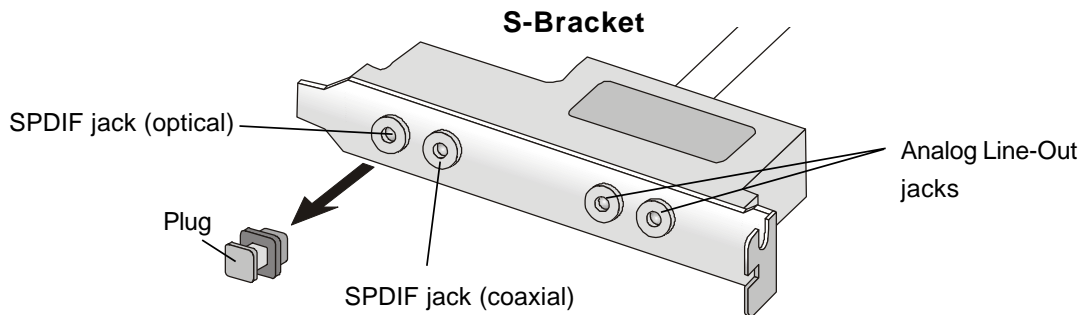

## Jumpers

The motherboard provides one jumper for you to set the computer's function. This section will explain how to change your motherboard's function through the use of the jumper.

### Clear CMOS Jumper: JBAT1

There is a CMOS RAM on board that has a power supply from external battery to keep the data of system configuration. With the CMOS RAM, the system can automatically boot OS every time it is turned on. If you want to clear the system configuration, use the JBAT1 (Clear CMOS Jumper) to clear data. Follow the instructions below to clear the data:

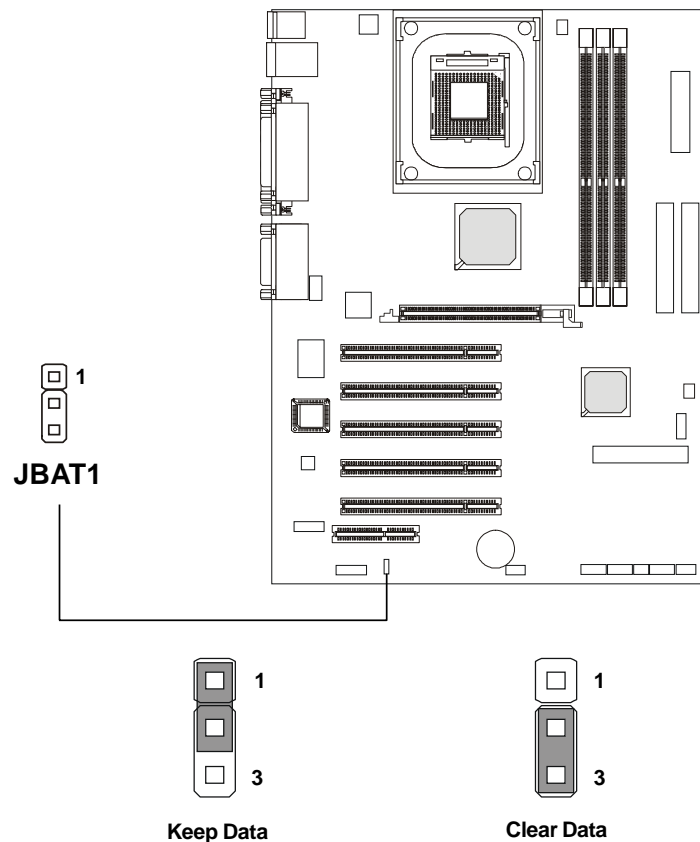

*You can clear CMOS by shorting 2-3 pin while the system is off. Then return to 1-2 pin position. Avoid clearing the CMOS while the system is on; it will damage the mainboard.*

# Slots

---

The motherboard provides one AGP slot, five 32-bit Master PCI bus slots, and one CNR slot.

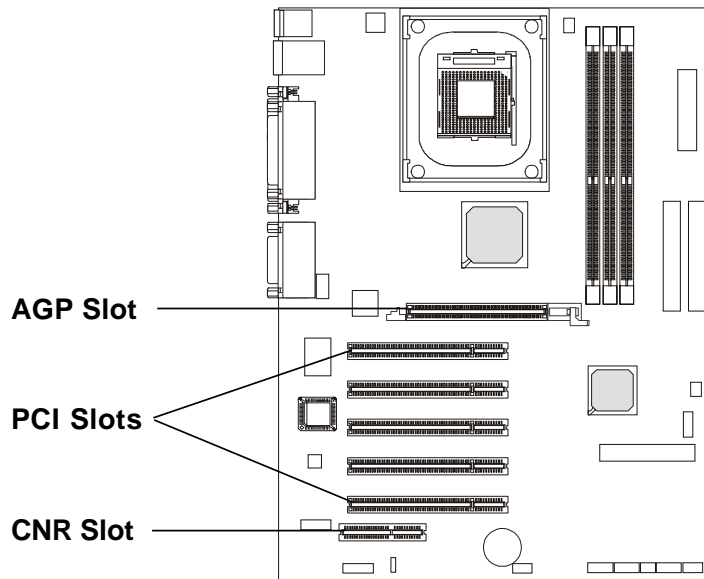

## AGP (Accelerated Graphics Port) Slot

The AGP slot allows you to insert the AGP graphics card. AGP is an interface specification designed for the throughput demands of 3D graphics. It introduces a 66MHz, 32-bit channel for the graphics controller to directly access main memory. The AGP slot **supports 2x and 4x only**.

## PCI Slots

Five PCI slots allow you to insert the expansion cards to meet your needs. When adding or removing expansion cards, make sure that you unplug the power supply first. Meanwhile, read the documentation for the expansion card to make any necessary hardware or software settings for the expansion card, such as jumpers, switches or BIOS configuration.

## CNR (Communication Network Riser) Slot

The CNR slot allows you to insert the CNR expansion cards. CNR is a specially designed network, audio, or modem riser card for ATX family motherboards. Its main processing is done through software and controlled by the motherboard's chipset. The CNR slot of the mainboard **supports audio and modem only**.

## **PCI Interrupt Request Routing**

The IRQ, abbreviation of interrupt request line and pronounced I-R-Q, are hardware lines over which devices can send interrupt signals to the microprocessor. The “AGP/PCI/USB/ACHIP” IRQ pins are typically connected to the PCI bus INT A# ~ INT D# pins as follows:

	Order 1	Order 2	Order 3	Order 4
AGP	INT A#	INT B#	INT C#	INT D#
PCI Slot 1	INT B#	INT C#	INT D#	INT A#
PCI Slot 2	INT C#	INT D#	INT A#	INT B#
PCI Slot 3	INT D#	INT A#	INT B#	INT C#
PCI Slot 4	INT A#	INT B#	INT C#	INT D#
PCI Slot 5	INT B#	INT C#	INT D#	INT A#
NEC USB 2.0	INT A#	INT B#	INT C#	INT D#
LAN Controller	INT C#	INT D#	INT A#	INT B#
ACHIP ATA 133	INT D#	INT A#	INT B#	INT C#

AGP & PCI Slot 4 & NEC USB2.0 shared.

PCI Slot 1 & PCI Slot 5 shared.

PCI Slot 2 & LAN shared.

PCI Slot 3 & ACHIP ATA133 shared.

*PCI Slot 1~5: Bus Master*

---

# AMI® BIOS Setup 3

This chapter provides information on the AMI® BIOS Setup program and allows you to configure the system for optimum use.

You may need to run the Setup program when:

- An error message appears on the screen during the system booting up, and requests you to run SETUP.
- You want to change the default settings for customized features.

## TOPICS

<i>Entering Setup</i>	3-2
<i>The Main Menu</i>	3-4
<i>Standard CMOS Features</i>	3-6
<i>Advanced BIOS Features</i>	3-8
<i>Advanced Chipset Features</i>	3-12
<i>Power Management Features</i>	3-14
<i>PNP/PCI Configurations</i>	3-18
<i>Integrated Peripherals</i>	3-21
<i>PC Health Status</i>	3-25
<i>Frequency/Voltage Control</i>	3-26
<i>Set Supervisor/User Password</i>	3-28
<i>Load Optimal/High Performance Defaults</i>	3-29



## **Entering Setup**

---

Power on the computer and the system will start POST (Power On Self Test) process. When the message below appears on the screen, press <DEL> key to enter Setup.

DEL:Setup    F11:Boot Menu    F12:Network boot    TAB:Logo

If the message disappears before you respond and you still wish to enter Setup, restart the system by turning it OFF and On or pressing the RESET button. You may also restart the system by simultaneously pressing <Ctrl>, <Alt>, and <Delete> keys.

## **Selecting the First Boot Device**

You are allowed to select the 1st boot device without entering the BIOS setup utility by pressing <F11>. When the same message as listed above appears on the screen, press <F11> to trigger the boot menu.

The POST messages might pass by too quickly for you to respond in time. If so, restart the system and press <F11> after around 2 or 3 seconds to activate the boot menu similar to the following.

<b>Select First Boot Device</b>		
Floppy	:	1st Floppy
IDE-0	:	IBM-DTLA-307038
CDROM	:	ATAPI CD-ROM DRIVE 40X M
[Up/Dn] Select	[RETURN] Boot	[ESC] cancel

The boot menu will list all the bootable devices. Select the one you want to boot from by using arrow keys and then pressing <Enter>. The system will boot from the selected device. The selection will not make changes to the settings in the BIOS setup utility, so next time when you power on the system, it will still use the original first boot device to boot up.

## Control Keys

<↑>	Move to the previous item
<↓>	Move to the next item
<<->	Move to the item in the left hand
<->>	Move to the item in the right hand
<Enter>	Select the item
<Esc>	Jumps to the Exit menu or returns to the main menu from a submenu
<+/PU>	Increase the numeric value or make changes
<-/PD>	Decrease the numeric value or make changes
<F5>	Restore the previous CMOS value from CMOS, only for Option Page Setup Menu
<F6>	Load Fail-Safe Defaults
<F7>	Load Optimized Defaults
<F10>	Save all the CMOS changes and exit

## Getting Help

After entering the Setup utility, the first screen you see is the Main Menu.

### Main Menu

The main menu displays the setup categories the BIOS supplies. You can use the arrow keys (↑↓) to select the item. The on-line description for the selected setup category is displayed at the bottom of the screen.

### Default Settings

The BIOS setup program contains two kinds of default settings: the BIOS Setup and High Performance defaults. Bios Setup defaults provide stable but minimal performance settings for all devices and the system, while High Performance defaults provide the best system performance but may affect the system stability.

## Chapter 3

# The Main Menu

---

Once you enter AMIBIOS NEW SETUP UTILITY, the Main Menu will appear on the screen. The Main Menu displays twelve configurable functions and two exit choices. Use arrow keys to move among the items and press <Enter> to enter the sub-menu.

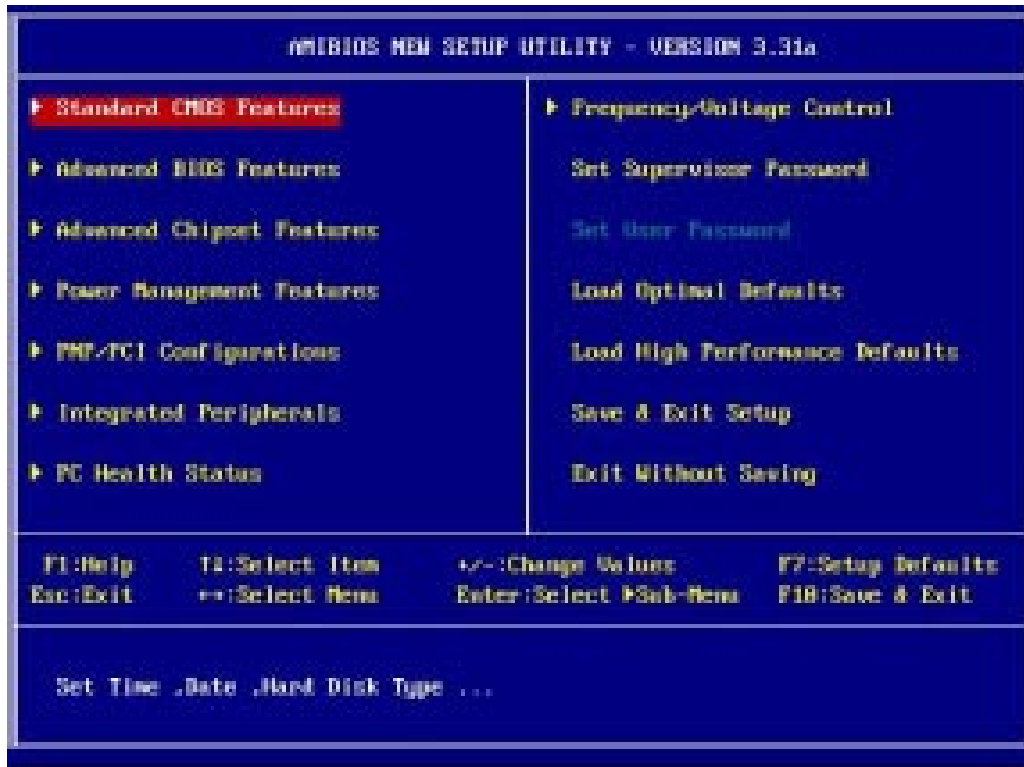

### Standard CMOS Features

Use this menu for basic system configurations, such as time, date etc.

### Advanced BIOS Features

Use this menu to setup the items of AMI® special enhanced features.

### Advanced Chipset Features

Use this menu to change the values in the chipset registers and optimize your system's performance.

### Power Management Features

Use this menu to specify your settings for power management.

**PNP/PCI Configurations**

This entry appears if your system supports PnP/PCI.

**Integrated Peripherals**

Use this menu to specify your settings for integrated peripherals.

**PC Health Status**

Use this menu to show the current status of your PC, such as temperature, Vcore, and other settings.

**Frequency/Voltage Control**

Use this menu to specify your settings for frequency/voltage control.

**Set Supervisor Password**

Use this menu to set Supervisor Password.

**Set User Password**

Use this menu to set User Password.

**Load Optimal Defaults**

Use this menu to load factory default settings into the BIOS for stable system performance operations.

**Load High Performance Defaults**

Use this menu to load the BIOS values for the best system performance, but the system stability may be affected.

**Save & Exit Setup**

Save changes to CMOS and exit setup.

**Exit Without Saving**

Abandon all changes and exit setup.

## Standard CMOS Features

The items inside STANDARD CMOS SETUP menu are divided into 9 categories. Each category includes none, one or more setup items. Use the arrow keys to highlight the item you want to modify and use the <PgUp> or <PgDn> keys to switch to the value you prefer.

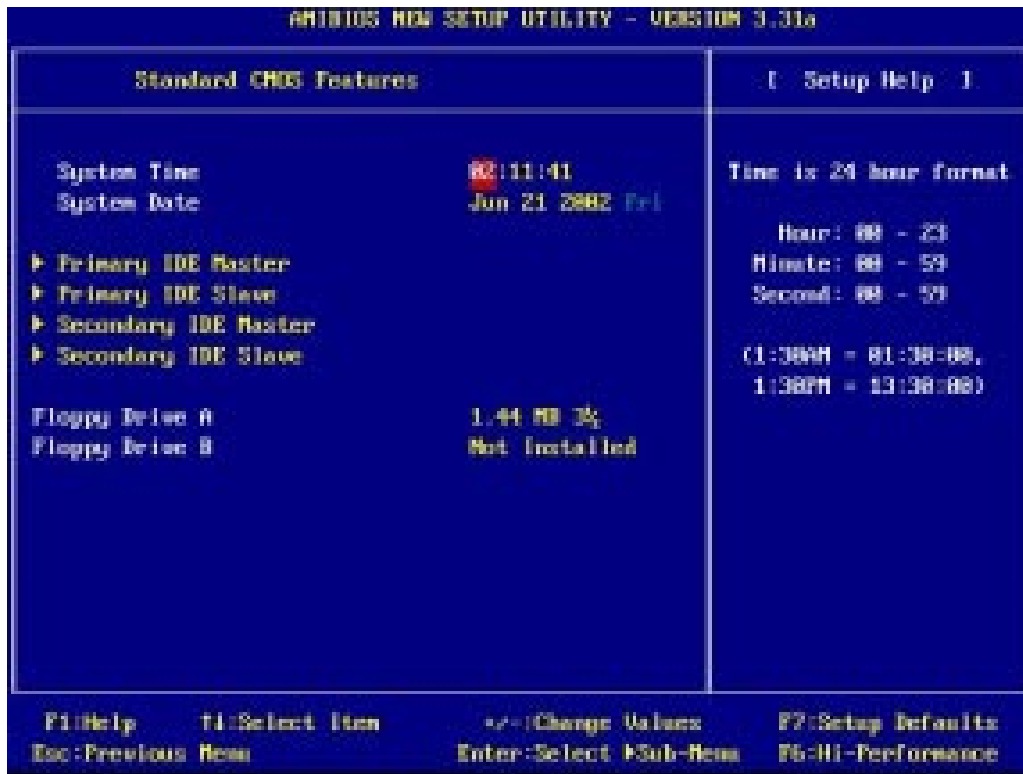

### System Date

This allows you to set the system to the date that you want (usually the current date). The format is <day><month> <date> <year>.

- day** Day of the week, from Sun to Sat, determined by BIOS. Read-only.
- month** The month from Jan. through Dec.
- date** The date from 1 to 31 can be keyed by numeric function keys.
- year** The year can be adjusted by users.

### System Time

This allows you to set the system time that you want (usually the current time). The time format is <hour> <minute> <second>.

### Pri Master/Pri Slave/Sec Master/Sec Slave

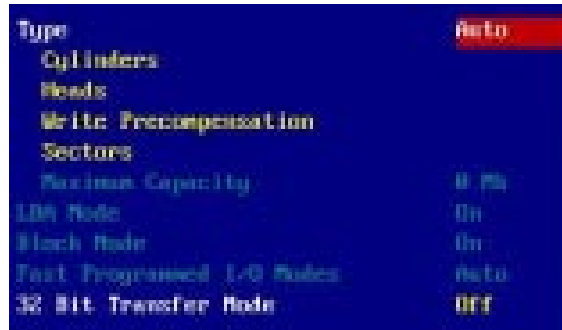

Press PgUp/<+> or PgDn/<-> to select the hard disk drive type. The specification of hard disk drive will show up on the right hand according to your selection.

Type	Select how to define the HDD parameters
Cylinders	Enter cylinder number
Heads	Enter head number
Write Precompensation	Enter write precomp cylinder
Sectors	Enter sector number
Maximum Capacity	Read the maximal HDD capacity
LBA Mode	Select <i>Auto</i> for a hard disk > 512 MB under Windows and DOS, or <i>Disabled</i> under Nerware and UNIX
Block Mode	Select <i>Auto</i> to enhance the hard disk performance
Fast Programmed I/O Modes	Select <i>Auto</i> to enhance hard disk performance by optimizing the hard disk timing
32 Bit Transfer Mode	Enable 32 bit to maximize the IDE had disk data transfer rate

### Floppy Drive A:/B:

This item allows you to set the type of floppy drives installed. Available options: *Not Installed*, *1.2 MB 5¼*, *720 KB 3½*, *1.44 MB 3½* and *2.88 MB 3½*.

## Chapter 3

# Advanced BIOS Features

---



### Quick Boot

Setting the item to *Enabled* allows the system to boot within 5 seconds since it will skip some check items. Available options: *Enabled* and *Disabled*.

### Full Screen Logo Show

This item enables you to show the company logo on the bootup screen. Settings are:

- |               |  |
|---------------|--|
| <i>Silent</i> | Shows the POST messages at boot.                       |
| <i>BIOS</i>   | Shows a still image (logo) on the full screen at boot. |

### Anti-Virus Warning

This item is to set the Virus Warning feature for IDE Hard Disk boot sector protection. If the function is enabled and any attempt to write data into this area is made, BIOS will display a warning message on the screen and beep. Available options: *Enabled* and *Disabled*.

## Boot Device Priority

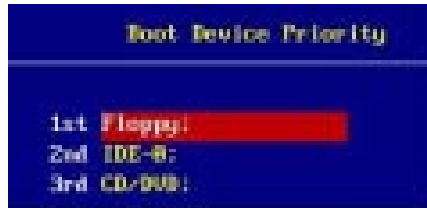

The items allow you to set the sequence of boot devices where AMIBIOS attempts to load the operating system. The settings are:

<i>Disabled</i>	Disable this sequence.
<i>IDE-0</i>	The system will boot from the first HDD.
<i>IDE-1</i>	The system will boot from the second HDD.
<i>IDE-2</i>	The system will boot from the third HDD.
<i>IDE-3</i>	The system will boot from the fourth HDD.
<i>Floppy</i>	The system will boot from floppy drive.
<i>ARMD-FDD</i>	The system will boot from any ARMD device, such as LS-120 or ZIP drive, that functions as a floppy drive.
<i>ARMD-HDD</i>	The system will boot from ARMD device, such as MO or ZIP drive, that functions as hard disk drive.
<i>CD/DVD</i>	The system will boot from the CD-ROM/DVD.
<i>Legacy SCSI</i>	The system will boot from the SCSI.
<i>Legacy Network</i>	The system will boot from the Network drive.
<i>BBS-0</i>	The system will boot from the first BBS (BIOS Boot Specification) compliant device.
<i>BBS-1</i>	The system will boot from the second BBS (BIOS Boot Specification) compliant device.
<i>BBS-2</i>	The system will boot from the third BBS (BIOS Boot Specification) compliant device.
<i>BBS-3</i>	The system will boot from the fourth BBS (BIOS Boot Specification) compliant device.
<i>USB FDD</i>	The system will boot from the USB FDD drive.
<i>USB CD-ROM</i>	The system will boot from the USB CD-ROM.
<i>USB HDD</i>	The system will boot from the USB HDD drive.
<i>USB RMD-FDD</i>	The system will boot from the USB RMD-FDD.
<i>USB RMD-HDD</i>	The system will boot from the USB RMD-HDD.



## Chapter 3



**Note:** Available settings for “Boot Device Priority” vary depending on the bootable devices you have installed. For example, if you did not install a floppy drive, the setting “Floppy” does not show up.

### Try Other Boot Devices

Setting the option to *Yes* allows the system to try to boot from other devices if the system fails to boot from the 1st/2nd/3rd boot device. Settings: *Yes, No*.

### S.M.A.R.T. for Hard Disks

This allows you to activate the S.M.A.R.T. (Self-Monitoring Analysis & Reporting Technology) capability for the hard disks. S.M.A.R.T is a utility that monitors your disk status to predict hard disk failure. This gives you an opportunity to move data from a hard disk that is going to fail to a safe place before the hard disk becomes offline. Settings: *Enabled* and *Disabled*.

### BootUpNum-Lock

This item is to set the Num Lock status when the system is powered on. Setting to *On* will turn on the Num Lock key when the system is powered on. Setting to *Off* will allow end users to use the arrow keys on the numeric keypad. Settings: *On, Off*.

### Password Check

This specifies the type of AMIBIOS password protection that is implemented. Setting options are described below.

Option	Description
Setup	The password prompt appears only when end users try to run Setup.
Always	A password prompt appears every time when the computer is powered on or when end users try to run Setup.

### Boot to OS/2

This allows you to run the OS/2<sup>®</sup> operating system with DRAM larger than 64MB. When you choose *No*, you cannot run the OS/2<sup>®</sup> operating system with DRAM larger than 64MB. But it is possible if you choose *Yes*.

### **Internal/External Cache**

Cache memory is additional memory that is much faster than conventional DRAM (system memory). When the CPU requests data, the system transfers the requested data from the main DRAM into cache memory, for even faster access by the CPU. The setting enables/disables the internal cache (also known as L1 or level 1 cache) or the external cache (also known as L2 or level 2 cache). Setting: *Enabled* and *Disabled*.

### **APIC Select**

This field is used to enable or disable the APIC (Advanced Programmable Interrupt Controller). Due to compliance with PC2001 design guide, the system is able to run in APIC mode. Enabling APIC mode will expand available IRQ resources for the system. Settings: *Enabled* and *Disabled*.

### **MPS Revision**

This field allows you to select which MPS (Multi-Processor Specification) version to be used for the operating system, when **APIC Function** is preset to *Enable*. You need to select the MPS version supported by your operating system. To find out which version to use, consult the vendor of your operating system. Settings: *1.4* and *1.1*.

## Advanced Chipset Features

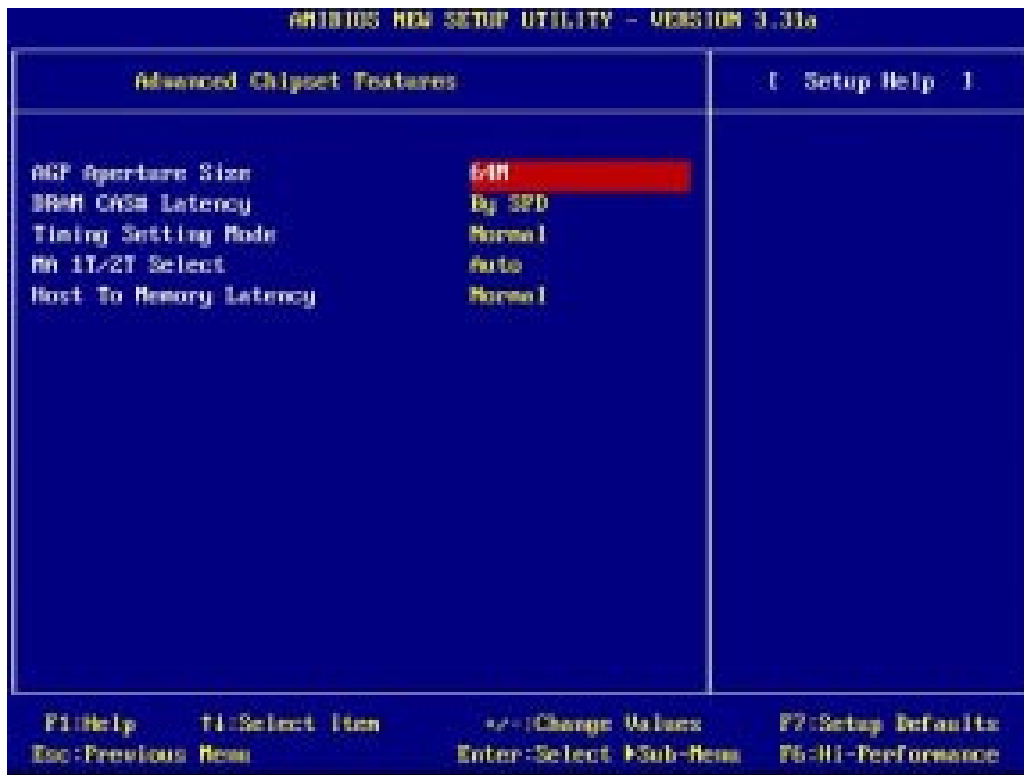

 **Note:** Change these settings only if you are familiar with the chipset.

### AGP Aperture Size

The field selects the size of the Accelerated Graphics Port (AGP) aperture. Aperture is a portion of the PCI memory address range dedicated for graphics memory address space. Host cycles that hit the aperture range are forwarded to the AGP without any translation. Settings: *4MB, 8MB, 16MB, 32MB, 64MB, 128MB, 256MB*.

### DRAM CAS# Latency

The field controls the CAS latency, which determines the timing delay before DRAM starts a read command after receiving it. Setting options: *By SPD, 3T, 2.5T, 2T*. *2T* increases system performance while *3T* provides more stable system performance. Setting to *By SPD* enables DRAM CAS# Latency automatically to be determined by BIOS based on the configurations on the SPD (Serial Presence Detect) EEPROM on the DRAM module.

### **Timing Setting Mode**

The DRAM timing is controlled by the DRAM Timing Registers. The Timings programmed into this register are dependent on the system design. Slower rates may be required in certain system designs to support loose layouts or slower memory. Setting options: *Safe Mode, Normal Mode, Fast Mode, Turbo Mode, Ultra Mode.*

### **MA 1T/2T Select**

This setting controls the DRAM command rate. Selecting *MA 1T* allows DRAM signal controller to run at 1T (T=clock cycle) rate. Selecting *MA 2T* makes DRAM signal controller run at 2T rate. 1T is faster than 2T. Setting options: *Auto, MA 2T, MA 1T.*

### **Host To Memory Latency**

When the system is running at Host and DRAM clock synchronous mode, you can set the field to *Fast* for better performance. If not, you have to select *Normal*. Settings: *Normal, Fast.*

## Chapter 3

# Power Management Features

---



### Power Button Function

This feature sets the function of the power button. Settings are:

- Power Off* The power button functions as normal on/off button.
- Suspend* When you press the power button, the computer enters the suspend/sleep mode, but if the button is pressed for more than four seconds, the computer is turned off.

### IPCA Function

This item is to activate the ACPI (Advanced Configuration and Power Management Interface) function. If your operating system is ACPI-aware, such as Windows 98SE/2000/ME, select *Yes*. Available options: *Yes* and *No*.

### Sleep State

This item specifies the power saving modes for ACPI function. Options are:

- S1/POS*      The S1 sleep mode is a low power state. In this state, no system context is lost (CPU or chipset) and hardware maintains all system context.
- S3/STR*      The S3 sleep mode is a lower power state where the information of system configuration and open applications/files is saved to main memory that remains powered while most other hardware components turn off to save energy. The information stored in memory will be used to restore the system when an “wake up” event occurs.
- Auto*          The system will decide when to enter S1 or S3 state.

### **Initialize VGA BIOS By S3**

This item allows the system to initialize the VGA BIOS if S3 (Suspend to RAM) resumes. Settings: *Enabled* and *Disabled*.

### **Power Management**

When *Disabled*, SMI will not be initialized, and complete power management functionality is removed until this option is set to *Enabled*. Settings are *Disabled* and *Enabled*.

### **Suspend Time Out**

After the selected period of system inactivity, all devices except the CPU shut off. Settings are *Disabled, 1, 2, 3, 4, 5, 10, 15, 20, 30 (min)*.

### **Hard Disk Time Out**

If HDD activity is not detected for the length of time specified in this field, the hard disk drive will be powered down while all other devices remain active. Settings are *Disabled, 1 through 15 Min*.

### **After AC Power Lost**

This setting specifies whether your system will reboot after a power failure or interrupts occurs. Available settings are:

- Power Off*      Leaves the computer in the power off state.
- Power On*        Reboots the computer.
- Last State*     Restores the system to the status before power failure or interrupt occurs.

## Chapter 3



### Set Wake Up Events

Press <Enter> to enter the sub-menu and the following screen appears:



### Wake Up On Ring, Wake Up On PME#, Resume on PS/2 Mouse, PS/2 MOUSE Wake Select Mode, USB Wakeup From S3

These items specify whether the system will be awakened from power saving modes when activity or input signal of the specified hardware peripheral or component is detected.

-  **Note 1:** You need to install a modem supporting power on function for Wake Up On Ring function.
-  **Note 2:** If you change these settings, you must reboot the system until it enters the operating system and then power off the system. By doing so, the changed settings will come into effect next time when you power on the system.
-  **Note 3:** You can specify the mouse wakeup method in the "PS/2 MOUSE Wake Select Mode". After you have selected the mode and enabled the "Resume on PS/2 Mouse" function, you need to use the specified mode for the system to resume on PS/2 Mouse.

### Keyboard PowerOnFunction



The item specify how the system will be awakened from power saving mode when input signal of the keyboard is detected. If set to *Specific Key*, <Ctrl+Alt+BackSpace> is the only one Power On event. If set to *Password*, please press <Enter> to input password and its maximum password is 5 character. Options are: *Disabled*, *Any Key*, *Specific Key* and *Password*.

### **Resume By Alarm**

If *Resume By Alarm* is set to *Enabled*, the system will automatically resume (boot up) on a specific date/hour/minute/second specified in these fields. Available settings for each item are:

Alarm Date	01~31, Every Day
Alarm Hour	00~23
Alarm Minute	00~59
Alarm Second	00~59



## PNP/PCI Configurations

This section describes configuring the PCI bus system and PnP (Plug & Play) feature. PCI, or Peripheral Component Interconnect, is a system which allows I/O devices to operate at speeds nearing the speed the CPU itself uses when communicating with its special components. This section covers some very technical items and it is strongly recommended that only experienced users should make any changes to the default settings.

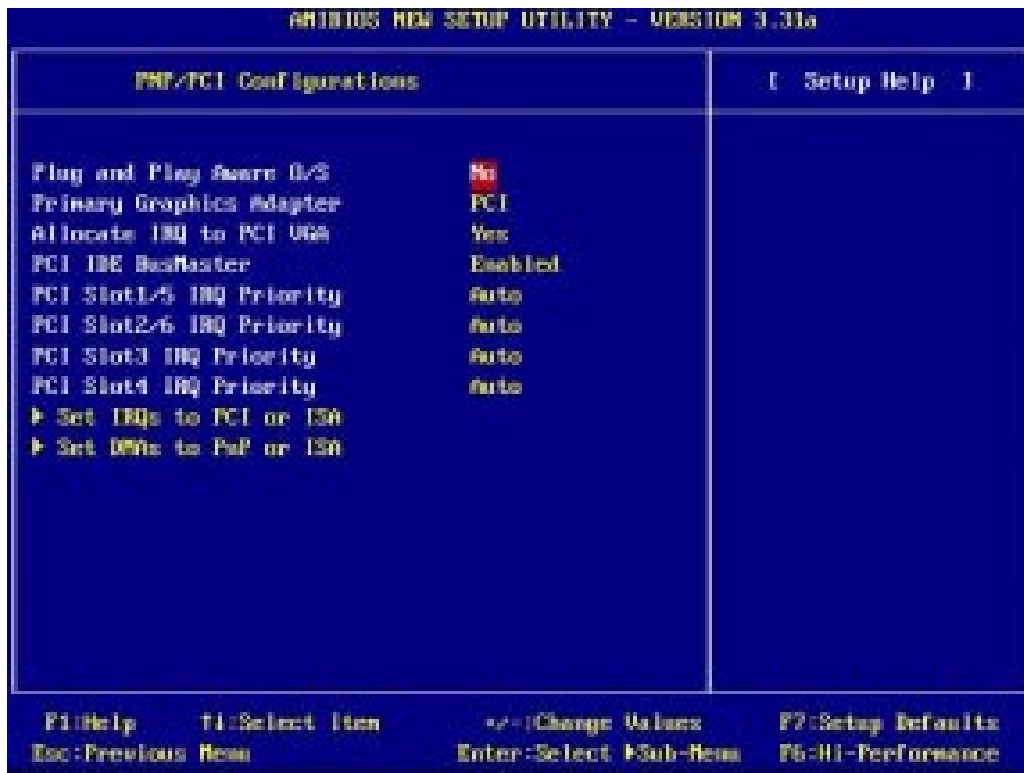

### Plug and Play Aware O/S

When set to *YES*, BIOS will only initialize the PnP cards used for booting (VGA, IDE, SCSI). the rest of the cards will be initialized by the PnP operating system like Windows 98/2000/ME. When set to *NO*, BIOS will initialize all the PnP cards. so select *YES* if the operating system is Plug and Play aware.

### Primary Graphics Adapter

This item specifies which VGA card is your primary graphics adapter. Settings: *PCI* and *AGP*.

### Allocate IRQ to PCI VGA

Set to *Yes* allows BIOS to assign an IRQ to PCI/VGA card. Select *No* if you want to release the IRQ.

### PCI IDE BusMaster

Set this option to *Enabled* to specify that the IDE controller on the PCI local bus has bus mastering capability. The settings are *Disabled* and *Enabled*.

### PCI Slot 1/5 IRQ, PCI Slot 2/6 IRQ, PCI Slot 3/4

This item specifies the IRQ line for each PCI slot, Settings: *3, 4, 5, 7, 9, 10, 11, Auto*. Selecting *Auto* allows BIOS to automatically determine the IRQ line for each PCI slot.

### Set IRQs to PCI or ISA

Press <Enter> to enter the sub-menu and the following screen appears:



### IRQ 3/4/5/7/9/10/11/14/15

These items specify the bus where the specified IRQ line is used. The settings determine if AMIBIOS should remove an IRQ from the pool of available IRQs passed to devices that are configurable by the system BIOS. The available IRQ pool is determined by reading the ESCD NVRAM. If more IRQs must be removed from the IRQ pool, the end user can use these settings to reserve the IRQ by assigning an *ISA/EISA* setting to it. Onboard I/O is configured by AMIBIOS. All IRQs used by onboard I/O are configured as *PCI/PnP*. If all IRQs are set to *ISA/EISA*, and IRQ 14/15 are allocated to the onboard PCI IDE, IRQ 9 will still be available for PCI and PnP devices. Available settings: *ISA/EISA* and *PCI/PnP*.

## Chapter 3

### Set DMAs to PnP or ISA

Press <Enter> to enter the sub-menu and the following screen appears:



#### **DMA Channel 0/1/3/5/6/7**

These items specify the bus that the system DMA (Direct Memory Access) channel is used.

The settings determine if AMIBIOS should remove a DMA from the available DMAs passed to devices that are configurable by the system BIOS. The available DMA pool is determined by reading the ESCD NVRAM. If more DMAs must be removed from the pool, the end user can reserve the DMA by assigning an *ISA/DISA* setting to it. Available options are: *PnP*, *ISA/DISA*.

## Integrated Peripherals

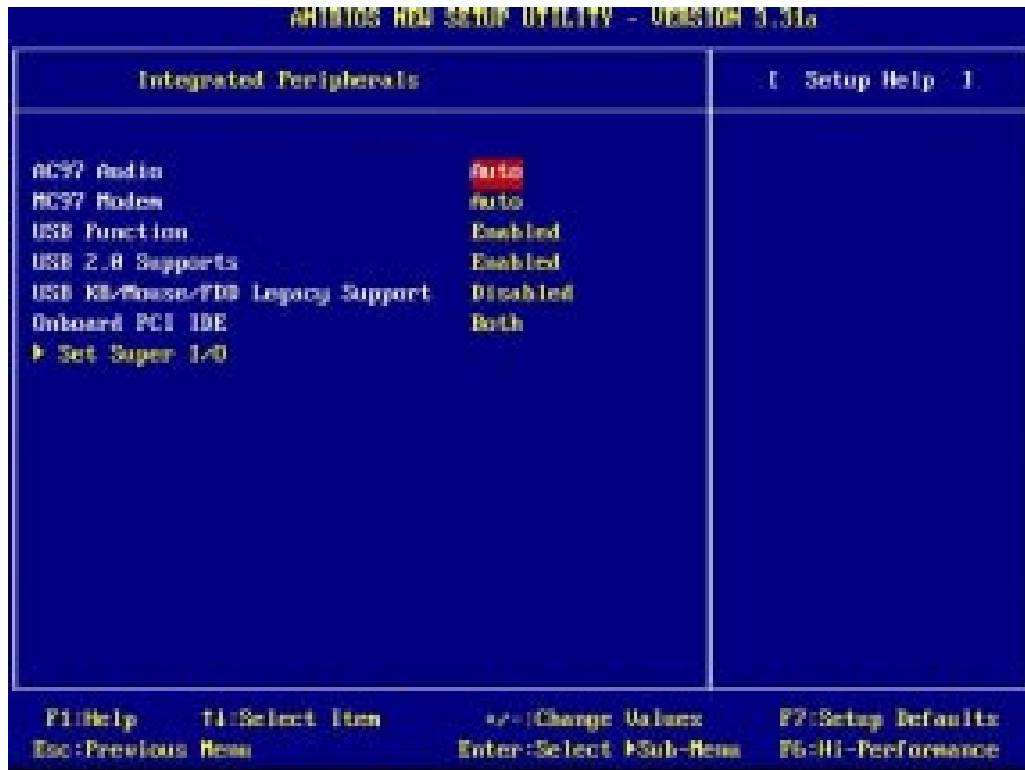

### AC97 Audio

*Enabled* allows the mainboard to detect whether an audio device is used. If the device is detected, the onboard AC'97 (Audio Codec'97) controller will be enabled; if not, it is disabled. Disable the controller if you want to use other controller cards to connect an audio device. Settings: *Enabled, Disabled*.

### MC97Modem

*Enabled* allows the mainboard to detect whether a modem is used. If a modem is used, the onboard MC'97 (Modem Codec'97) controller will be enabled; if not, it is disabled. Disable the controller if you want to use other controller cards to connect to a modem. Settings: *Enabled, Disabled*.

### USB Function

This setting is used to enable/disable the onboard USB controllers. Settings: *Enabled, Disabled*.

## Chapter 3

### USB 2.0 Supports

Set to *Enabled* if your need to use any USB 2.0 device in the operating system that does not support or have any USB 2.0 driver installed, such as DOS and SCO Unix. Setting options: *Disabled, Enabled*.

### USB KB/Mouse/FDD Legacy Support

Set to *Enabled* if your need to use any USB KB/Mouse/FDD device in the operating system that does not support or have any USB driver installed. Setting options: *Disabled, Enabled*.

### Onboard PCI IDE

This setting controls the on-chip IDE controller. Setting options: *Disabled, Primary, Secondary, Both*.

### Set Super I/O

Press <Enter> to enter the sub-menu and the following screen appears:



### OnBoardFDC

This is used to enable or disable the onboard Floppy controller.

Option	Description
Auto	BIOS will automatically determine whether to enable the onboard Floppy controller or not.
Enabled	Enables the onboard Floppy controller.
Disabled	Disables the onboard Floppy controller.

### **OnBoard Serial Port A/B**

These items specify the base I/O port addresses of the onboard Serial Port 1 (COM A)/Serial Port 2 (COM B). Selecting *Auto* allows AMIBIOS to automatically determine the correct base I/O port address. Settings: *Auto, 3F8/COM1, 2F8/COM2, 3E8/COM3, 2E8/COM4* and *Disabled*.

### **Serial Port B Mode**

This item sets the operation mode for Serial Port B. Settings: *Normal, 1.6uS, 3/16 Baud* and *ASKIR* (the last three operation modes are setting options for IR function).

### **IR Pin Select**

Set to *IRRX/IRTX* when using an internal IR module connected to the IR connector. Set to *SINB/SOUTB* when connecting an IR adapter to COM 2.

### **OnBoard Parallel Port**

These items specify the base I/O port addresses of the onboard parallel port. Selecting *Auto* allows AMIBIOS to automatically determine the correct base I/O port address. Settings: *Auto, Disable, 378h, 278h, 3BCh*.

### **Parallel Port Mode**

This item selects the operation mode for the onboard parallel port: *Normal, Bi-Dir, EPP or ECP*.

### **EPP Version**

The item selects the EPP version used by the parallel port if the port is set to *EPP* mode. Settings: *EPP1.9* and *EPP1.7*.

### **Parallel Port IRQ**

When *Parallel Port* is set to *Auto*, the item shows *Auto* indicating that BIOS determines the IRQ for the parallel port automatically. Settings: *5, 7, Auto*.

## **Chapter 3**

### **Parallel Port DMA Channel**

This feature needs to be configured only when *Port Mode* is set to the *ECP* mode. When Parallel Port is set to *Auto*, the field will show *Auto* indicating that BIOS automatically determines the DMA channel for the parallel port. Available options: *0, 1, 3, Auto*.

### **OnBoard Midi Port**

The field specifies the base I/O port address for the onboard Midi Port. The settings are: *Disabled, 330h, 300h*.

### **Midi IRQ Select**

The item is used to select the IRQ line for onboard Midi port. Options: *5, 10, 11*.

### **OnBoard Game Port**

This item is used to specify the address for the onboard game port. The settings are: *Disabled, 200h, and 208h*.

## PC Health Status

This section shows the status of your CPU, fan, warning for overall system status.

PC Health Status		Setup Help 1
Vcore	1.980 V	
+3.3V	3.280 V	
+5.0V	5.100 V	
+12V	11.692 V	
-12V	-11.100 V	
-5.0V	-1.725 V	
Battery Voltage	3.130 V	
SYSTEM Fan Speed	0 RPM	
CPU FAN Speed	3600 RPM	
SYSTEM Temperature	32°C/89°F	
CPU Temperature	33°C/91°F	

F1:Help    F11:Select Item    +/-:Change Values    F7:Setup Defaults  
 Esc:Previous Menu    Enter:Select Sub-Menu    F5:HI-Performance

**Vcore, +3.3V, +5.0V, +12V, -12V, -5.0V, Battery Voltage, SYSTEM Fan Speed, CPU FAN Speed, SYSTEM Temperature, CPU Temperature**

These items display the current status of all of the monitored hardware devices/components such as system voltages, temperatures and fan speeds.



## Chapter 3

# Frequency/Voltage Control

This section describes how to set the Chassis Intrusion feature, CPU FSB frequency, monitor the current hardware status including CPU/system temperatures, CPU/System Fan speeds, Vcore etc. Monitor function is available only if there is hardware monitoring mechanism onboard.

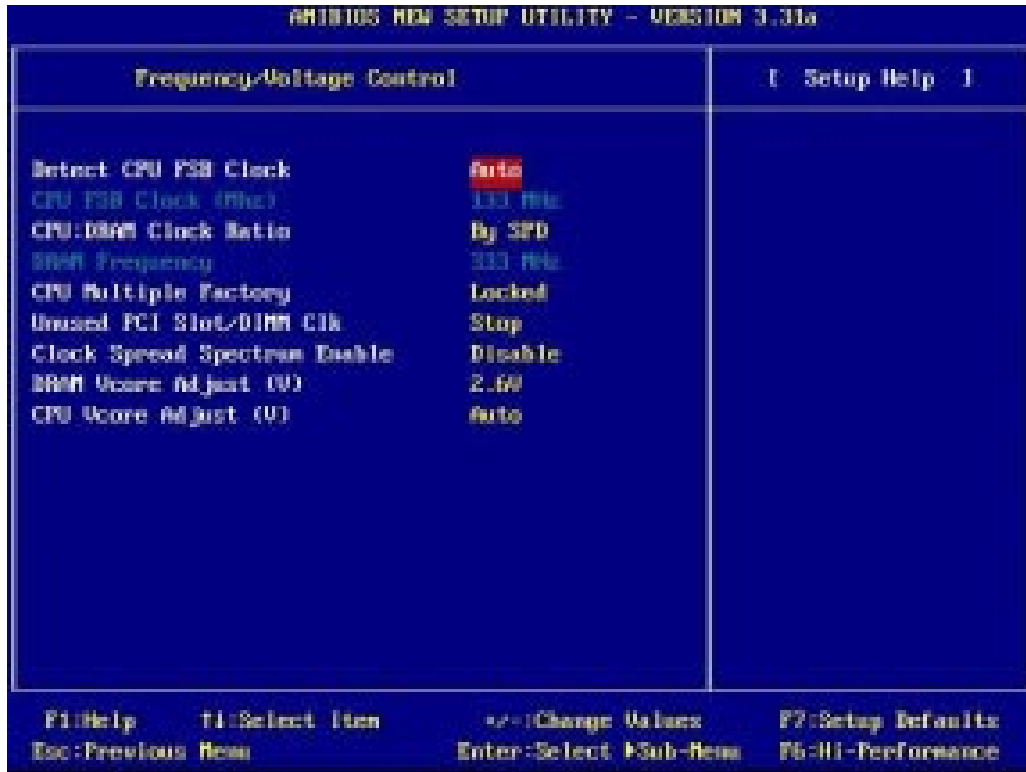

### Detect CPU FSB Clock

This setting enables you to detect the CPU Front Side Bus clock frequency. Setting options: *Auto, Manual*.

### CPU FSB Clock (Mhz)

This setting shows the CPU Front Side Bus clock frequency. Setting option: *default*.

### CPU: DRAM Clock Ratio

This setting controls the ratio of CPU FSB Clock & DRAM Frequency to enable the CPU & DRAM to run at different frequency combinations. Please note that the setting options vary according to the CPU FSB Clock preset.

CPU FSB Clock	Setting Options
100MHz	1:1, 3:4, 3:5, 2:3, By SPD
101~132MHz	1:1, 3:4, 3:5, 2:3
133~160MHz	4:3, 1:1, 4:5, By SPD
161~200MHz	Auto

### DRAM Frequency

This item shows the current frequency of DDR DRAM. (read only)

### CPU Multiple Factory

This item allows users to select the CPU multiplier value. The default value of this item is *Locked*.

### Unused PCI Slot/DIMM Clk

This setting enables you to stop or activate the unused PCI slot & DIMM clock. Setting options: *Stop, Action*.

### Clock Spread Spectrum Enable

This item is used to configure the clock generator's Spread Spectrum feature. Settings: *Disabled, Enabled*. Always disable the feature when overclocking the processor.

### CPU Vcore Adjust (V)

This item allows you to adjust the CPU core voltage. Settings:

*For Willamette processor: 1.725, 1.775, 1.800, 1.825, 1.850, Auto.*

*For Northwood processor: 1.475, 1.525, 1.550, 1.575, 1.600, Auto.*

Please note that it may be dangerous to adjust the Vcore over 10%.

### DRAM Vcore Adjust (V)

This setting is used to adjust the DRAM core voltage (Vcore), making overclocking possible. Setting options: *2.5V to 2.8V* at 0.1V increment.

## Set Supervisor/User Password

---

When you select this function, a message as below will appear on the screen:

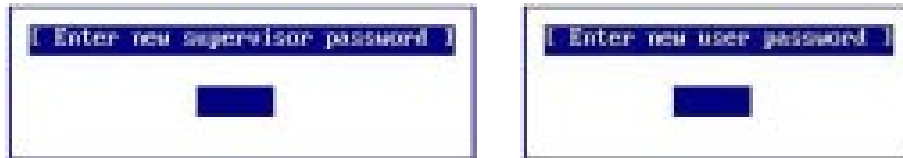

Type the password, up to six characters in length, and press <Enter>. The password typed now will replace any previously set password from CMOS memory. You will be prompted to confirm the password. Retype the password and press <Enter>. You may also press <Esc> to abort the selection and not enter a password.

To clear a set password, just press <Enter> when you are prompted to enter the password. A message will show up confirming the password will be disabled. Once the password is disabled, the system will boot and you can enter Setup without entering any password.

When a password has been set, you will be prompted to enter it every time you try to enter Setup. This prevents an unauthorized person from changing any part of your system configuration.

Additionally, when a password is enabled, you can also have AMIBIOS to request a password each time the system is booted. This would prevent unauthorized use of your computer. The setting to determine when the password prompt is required is the Password Check of the ADVANCED BIOS FEATURES menu. If the Password Check is set to *Always*, the password is required both at boot and at entry to Setup. If set to *Setup*, password prompt only occurs when you try to enter Setup.



**Note:**

*Supervisor password:* Can enter and change the settings of the setup menu.

*User password:* Can only enter but do not have the right to change the settings of the setup menu.  
(will be disabled if no supervisor password is preset)

## Load Optimal/High Performance Defaults

---

The two options on the main menu allow users to restore all of the BIOS settings to High Performance defaults or Optimal defaults. The High Performance Defaults are the default values set by the mainboard manufacturer for the best system performance but probably will cause a stability issue. The Optimal Defaults are the default values also set by the mainboard manufacturer for stable performance of the mainboard.

When you select Load Optimal Defaults, a message as below appears:



Pressing 'Enter' loads the default values that are factory settings for stable system performance.

When you select Load High Performance Defaults, a message as below appears:

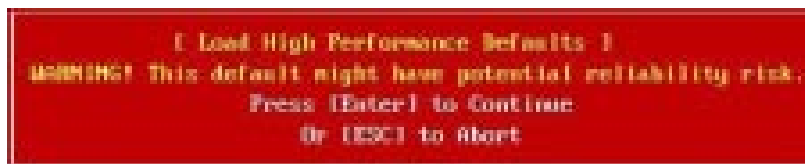

Pressing 'Enter' loads the default BIOS values that enable the best system performance but may lead to a stability issue.



**WARNING!**

***The Load High Performance Defaults option is for power or overclocking users only. Use of high performance defaults will tighten most timings to increase the system performance. Therefore, a high-end system configuration is a must, which means you need high-quality VGA adapter, RAM and so on. We don't recommend that users should apply the high performance defaults in their regular systems. Otherwise, the system may become unstable or even crash. If the system crashes or hangs after enabling the feature, please CLEAR CMOS DATA to resolve the problem. For more information, refer to "Clear CMOS Jumper:JBAT1" in Chapter 2.***

## ***Appendix A: Using 4- or 6-Channel Audio Function***

The motherboard is equipped with Realtek ALC650 chip, which provides support for 6-channel audio output, including 2 Front, 2 Rear, 1 Center and 1 Subwoofer channel. ALC650 allows the board to attach 4 or 6 speakers for better surround sound effect. The section will tell you how to install and use 4-/6-channel audio function on the board.

### **TOPICS**

<i>Installing the Audio Driver</i>	<i>A-2</i>
<i>Using 4-/6-Channel Audio Function</i>	<i>A-4</i>
<i>Testing the Connected Speakers</i>	<i>A-11</i>
<i>Playing KaraOK</i>	<i>A-12</i>

## Appendix A

# Installing the Audio Driver

---

You need to install the driver for Realtek ALC650 chip to function properly before you can get access to 4-/6-channel audio operations. Follow the procedures described below to install the drivers for different operating systems.

## Installation for Windows 98SE/ME/2000/XP

For Windows® 2000, you must install Windows® 2000 Service Pack2 or later before installing the driver.

The following illustrations are based on Windows® XP environment and could look slightly different if you install the drivers in different operating systems.

1. Insert the companion CD into the CD-ROM drive. The setup screen will automatically appear.
2. Click **Avance ALC650 Sound Drivers**.

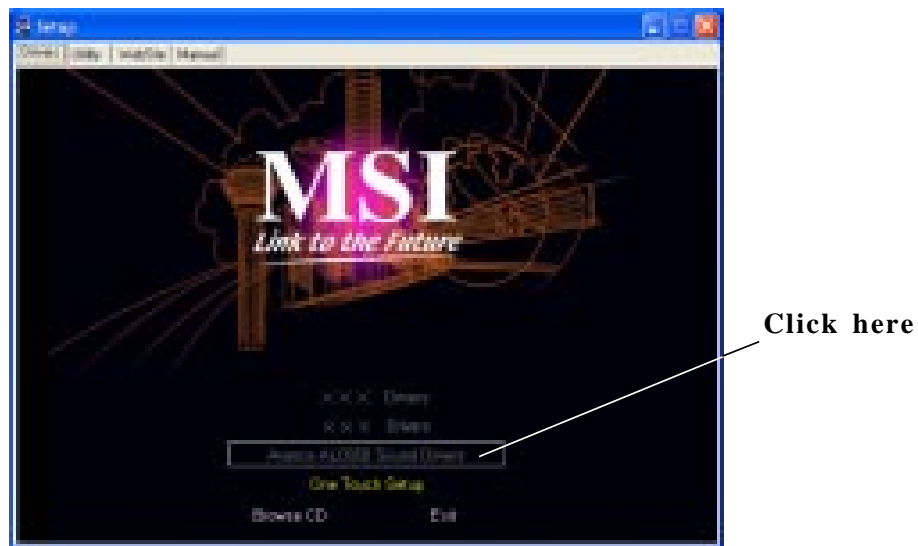

3. Click **Next** to start installing files into the system.

## Using 4- or 6-Channel Audio Function

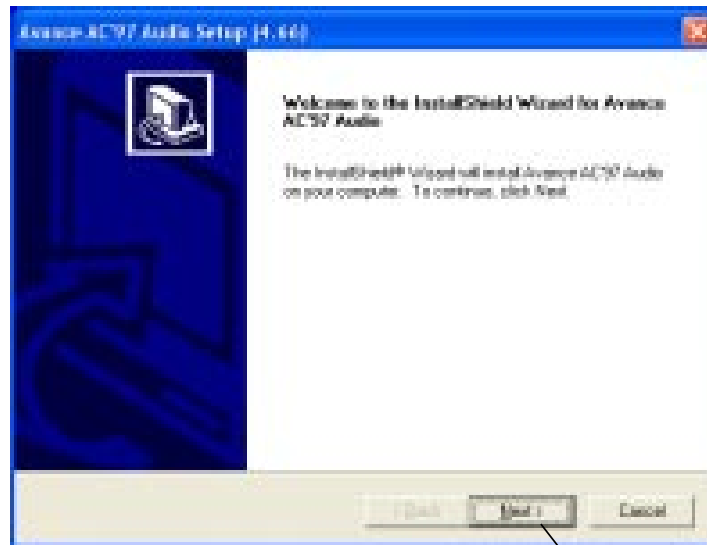

Click here

4. Click **Finish** to restart the system.

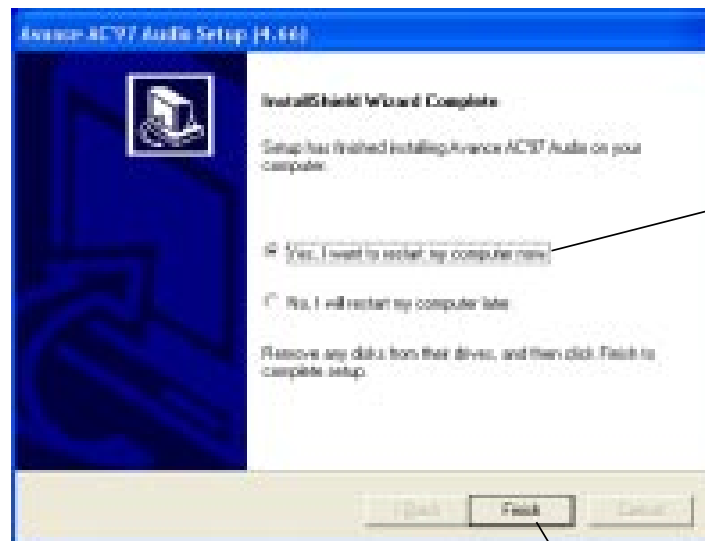

Select this option

Click here

# Using 4- or 6-Channel Audio Function

---

After installing the audio driver, you are able to use the 4-/6-channel audio feature now. To enable 4- or 6-channel audio operation, first connect 4 or 6 speakers to the appropriate audio connectors, and then select 4- or 6-channel audio setting in the software utility.

There are two ways to utilize the function and connect the speakers to your computer:

- *Use the optional S-Bracket.* If your motherboard supports S-Bracket and you have installed S-Bracket in the computer, you can connect two speakers to back panel's Line-Out connector, and the rest of speakers to S-Bracket.
- *Use the back panel only.* If you do not have a S-Bracket, you can connect all speakers to the audio connectors on the back panel.

## Attaching Speakers

To perform multichannel audio operation, connect multiple speakers to the system. You should connect the same number of speakers as the audio channels you will select in the software utility.



### **Note:**

*If the Center and Subwoofer speaker exchange their audio channels when you play video or music on the computer, a converter may be required to exchange center and subwoofer audio signals. You can purchase the converter from a speaker store .*

## Using S-BRACKET connectors:

S-Bracket is an optional accessory. It gives access to analog and digital audio output by integrating both SPDIF (Sony & Philips Digital Interface) and analog LINE OUT connectors. To use the S-Bracket, you should select correct setting in the software utility. For information about the setting, refer to *Selecting 4- or 6-Channel Setting* later in the section.

Connector configurations for 2-, 4- and 6-channel using S-Bracket are described below:



## Using 4- or 6-Channel Audio Function

### 2-Channel Analog Audio Output

We recommend that you should still attach the speakers to BACK PANEL's Line Out connector during 2-channel audio mode even though S-Bracket's Line Out connectors function properly.

- 1 Line Out (*Front channels*)
- 2 Line In
- 3 MIC

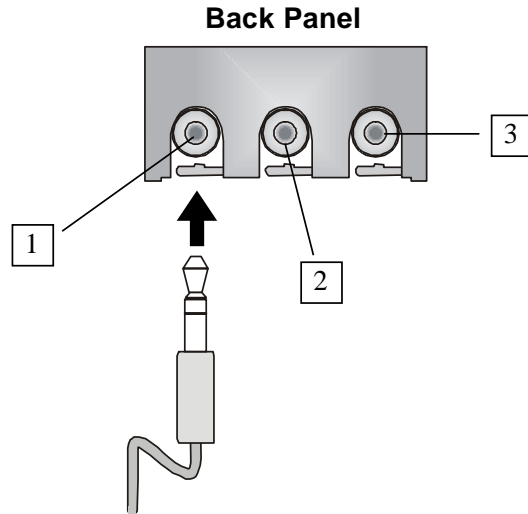

### 4-Channel Analog Audio Output

- 1 Line Out (*Front channels*)
- 2 Line In
- 3 MIC
- 4 Optical SPDIF jack
- 5 Coaxial SPDIF jack
- 6 Line Out (*Center and Subwoofer channel*)
- 7 Line Out (*Rear channels*)

#### Description:

Connect two speakers to back panel's Line Out connector and two speakers to one Line Out connector of S-Bracket.

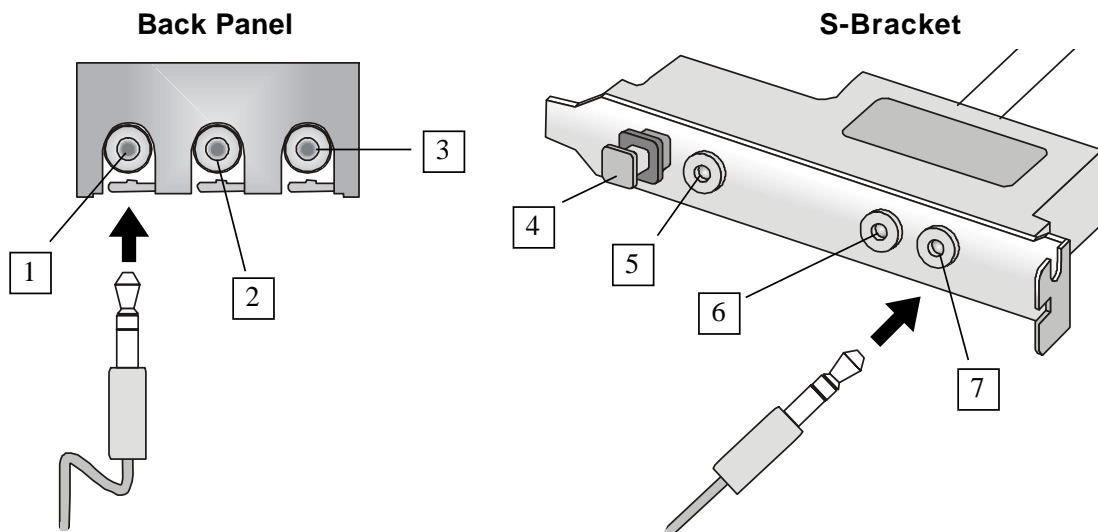

## Appendix A

### 6-Channel Analog Audio Output

- 1 Line Out (*Front channels*)
- 2 Line In
- 3 MIC
- 4 Optical SPDIF jack
- 5 Coaxial SPDIF jack
- 6 Line Out (*Center and Subwoofer channel*)
- 7 Line Out (*Rear channels*)

Description:

Connect two speakers to back panel's Line Out connector and four speakers to both Line Out connectors of S-Bracket.

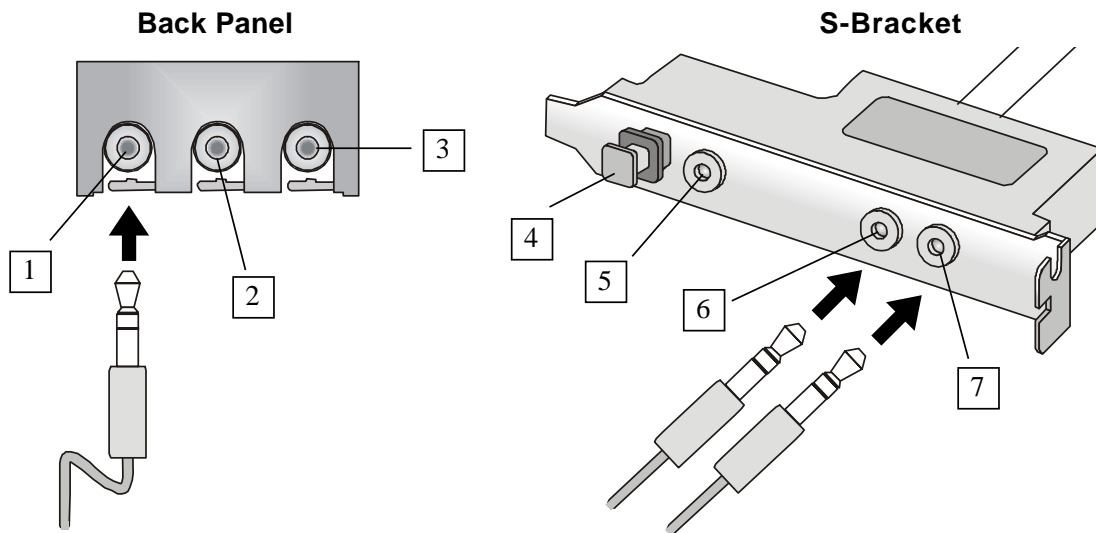

### Digital Audio Output (2-Channel only)

For digital audio output, use the SPDIF (Sony & Philips Digital Interface) connectors supplied by *S-Bracket*. First, connect the SPDIF speakers to the appropriate SPDIF jack, and then select the audio channel you desire through the control panel of speakers. The SPDIF connectors support 2-channel audio operation only.

*S-Bracket* offers two types of SPDIF jacks: one for fiber-optic cable and the other for coaxial cable. Select the connector according to the type of your SPDIF speakers.

## Using 4- or 6-Channel Audio Function

- 1 Optical SPDIF jack
- 2 Coaxial SPDIF jack
- 3 Line Out
- 4 Line Out

### Description:

Select the correct type of SPDIF jack to connect SPDIF speakers. For optical connection, remove the plug from the S-Bracket before inserting the fiber-optic cable to it.

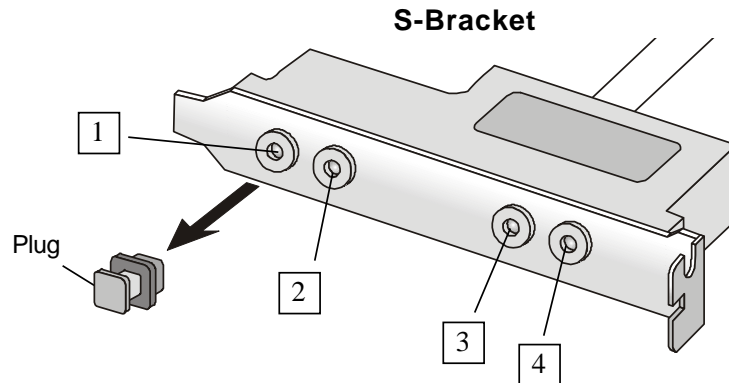

### Using BACK PANEL connectors only:

The audio connectors on the back panel already provide 2-channel analog audio output function. The back panel's audio connectors can be transformed to 4-/6-channel analog audio connectors automatically when you select correct setting in the software utility. For information about the setting, refer to *Selecting 4- or 6-Channel Setting* later in the section.

Make sure all speakers are connected to *Line Out* connectors. Diverse connector configurations for 2-, 4- and 6-channel using back panel connectors are described below:

### 2-Channel Analog Audio Output

- 1 Line Out (*Front channels*)
- 2 Line In
- 3 MIC

### Description:

Line Out, Line In and MIC functions all exist under 2-channel configuration.

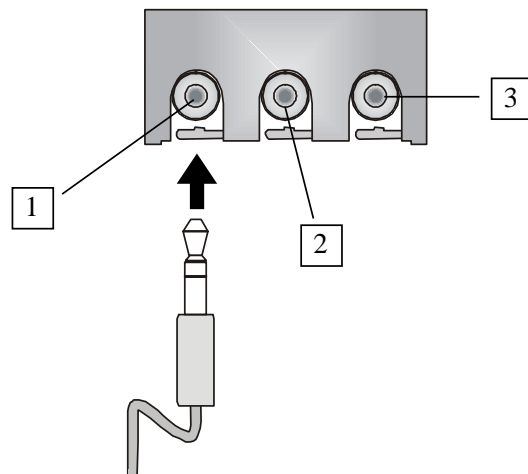

## Appendix A

### 4-Channel Analog Audio Output

- 1 Line Out (*Front channels*)
- 2 Line Out (*Rear channels*)
- 3 MIC

Description:

Line In is converted to Line Out function under 4-channel configuration.

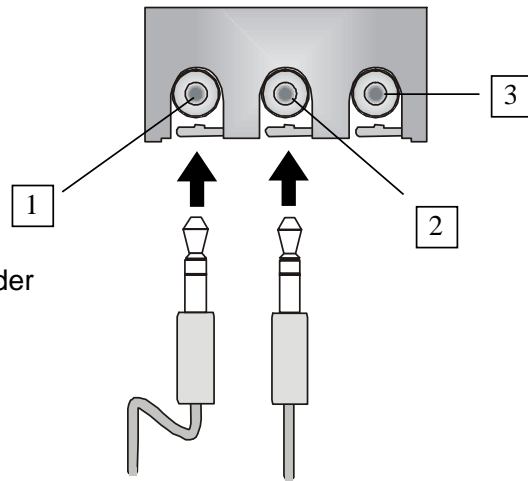

### 6-Channel Analog Audio Output

- 1 Line Out (*Front channels*)
- 2 Line Out (*Rear channels*)
- 3 Line Out (*Center and Subwoofer channel*)

Description:

Both Line In and MIC are converted to Line Out function under 6-channel configuration.

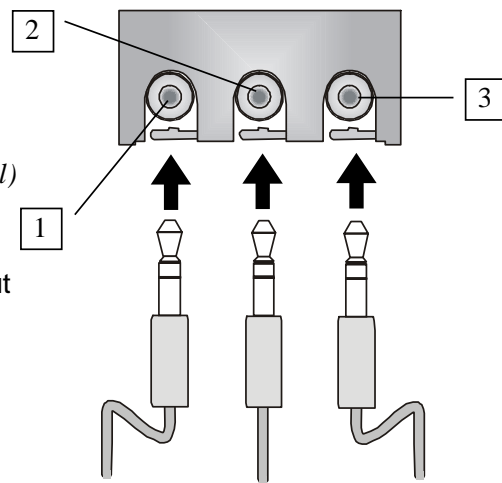

## Using 4- or 6-Channel Audio Function

### Selecting 4- or 6-Channel Setting

1. Click the audio icon  from the window tray at the bottom of the screen.
2. Select any surround sound effect you prefer from the “Environment” pull-down menu under the **Sound Effect** tab.

Click here and the pull-down menu will appear

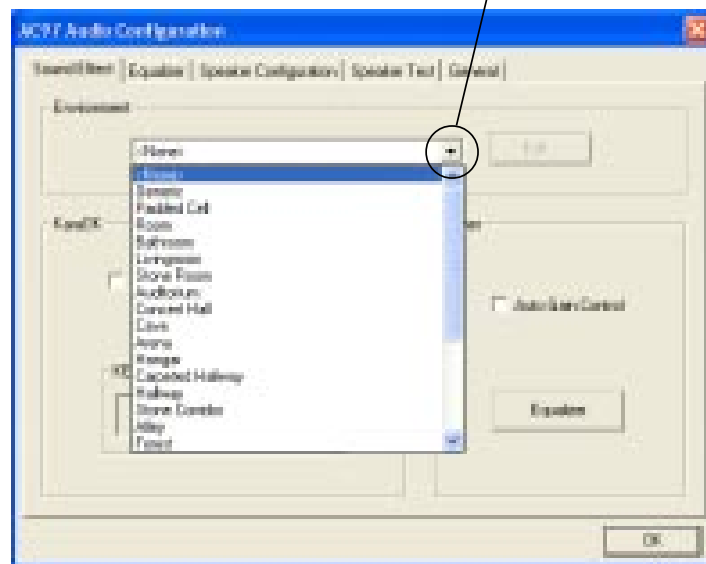

3. Click the **Speaker Configuration** tab.

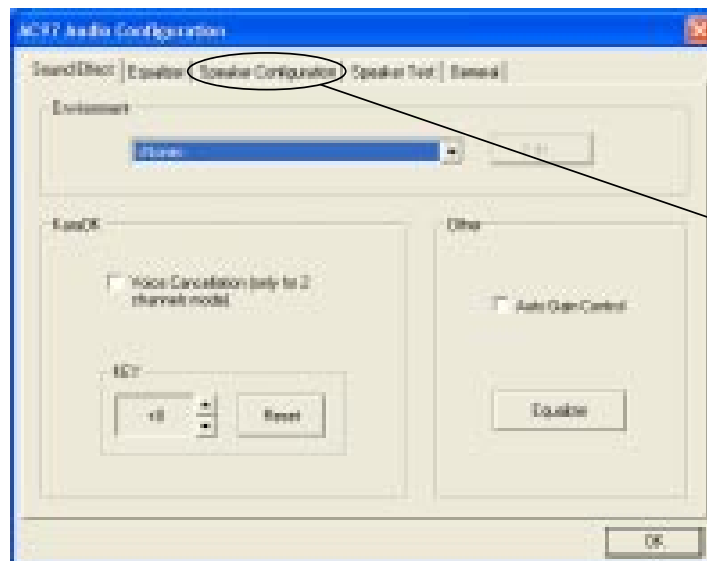

Click here

## Appendix A

4. The following window appears.



5. Select the multi-channel operation you prefer from **No. of Speakers**.
6. Select the audio device that you wish to use as audio output connectors. There are two options for this:

- Use S-Bracket Make sure **Use S-Bracket** is NOT selected if you want to use audio connectors on the back panel only.

 Refer to “Using *BACK PANEL* connectors only” earlier in the section for how to attach speakers.

- Use S-Bracket Select **Use S-Bracket** if you want to use audio connectors supplied by the connected S-Bracket.

 Refer to “Using *S-BRACKET* connectors” earlier in the section for how to attach speakers.

7. Click **OK**.



### Note:

It is useless to select “Use S-Bracket” if your motherboard does not support or have the S-Bracket installed in the system.

## Testing the Connected Speakers

---

To ensure 4- or 6-channel audio operation works properly, you may need to test each connected speaker to make sure every speaker work properly. If any speaker fails to sound, then check whether the cable is inserted firmly to the connector or replace the bad speakers with good ones.

### Testing Each Speaker:

1. Click the audio icon  from the window tray at the bottom of the screen.
2. Click the **Speaker Test** tab.
3. The following window appears.

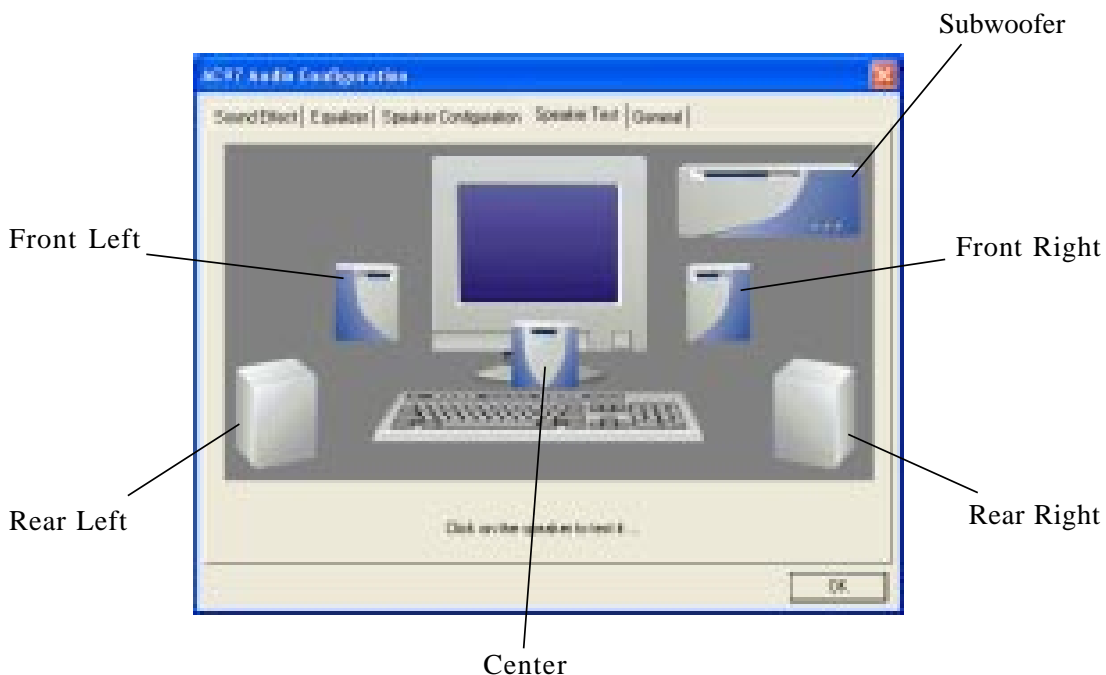

4. Select the speaker which you want to test by clicking on it.



**Note:**

*6 speakers appear on the "Speaker Test" window only when you select "6 channels mode" in the "No. of Speakers" column. If you select "4 channels mode", only 4 speakers appear on the window.*

## Playing KaraOK

---

The KaraOK function will automatically remove human voice (lyrics) and leave melody for you to sing the song. **The function is applied only for 2-channel audio operation**, so make sure “2 channels mode” is selected in the “No. of Speakers” column before playing KaraOK.

### Playing KaraOK:

1. Click the audio icon  from the window tray at the bottom of the screen.
2. Make sure the **Sound Effect** tab is selected.
3. Select **Voice Cancellation** in the “KaraOK” column.

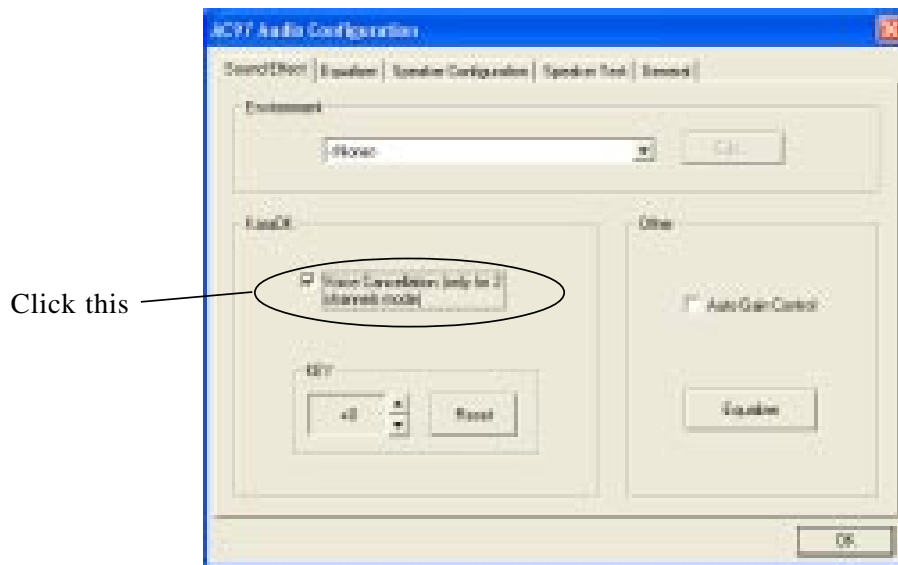

4. Click **OK**.